



PowerLED Downlight Installation and Operation Manual

Hatteras



Hatteras with Base



Hatteras with
Base & Switch



OVERVIEW

Imtra PowerLED fixtures are uniquely suited for marine, automotive, and architectural lighting applications. They have been engineered specifically to take advantage of the latest LED (Light Emitting Diode) technology offering superior reliability, minimal power consumption, and far less radiated heat than traditional incandescent light sources. When installed properly, these products will provide years of flawless performance.

Most of the downlights in this series are offered with a choice of LED color in addition to bezel finish options. When installed and operated with an Imtra PWM LED dimmer, up to 30 fixtures can be controlled simultaneously from multiple locations.

We encourage you to read this installation guide thoroughly as there are particular electronic & electrical criteria and other critical installation details that should be met in order to assure many years of enjoyment from your new PowerLED product(s).

The Imtra PowerLED family of products is compatible with several Automated Control Systems. For more information on integrating our PowerLEDs with your control system, please contact us at 508-995-7000 or via email at lighting@imtra.com.

- 1 -

SPECIFICATIONS

	Hatteras	Hatteras with Base	Hatteras with Base & Switch
Trim Ring Diameter	2.85" (72mm)	2.85" (72mm)	6.10" (155mm)
Mounting Base Diam.	N/A	2.85" (72mm)	3.70" (94mm)
Height	0.24" (6mm)	0.77" (20mm)	1.02" (26mm)
Cutout Diameter	2.13" (54mm)	N/A	N/A
Recess Depth	0.54" (14mm)	N/A	N/A
Input Voltage Range	10-30 VDC		
Power Consumption	3.2 Watts		
IP Rating	IP65*		

* IP65: "Protected from the ingress of dust and low pressure jets of water from all directions"

- 2 -

PHYSICAL INSTALLATION

It is imperative that the lights are mounted in such a location that the fixtures are protected from the rear against water exposure.

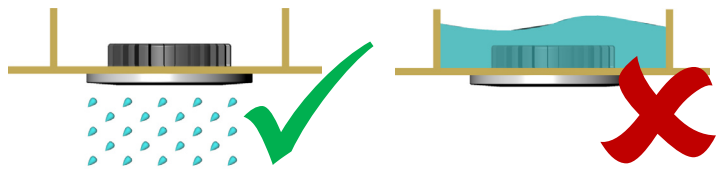

Also, it is important that the lights are mounted with airspace around the heat sink housing to allow for convective cooling of the lights. For recessed applications (this does not apply for surface mount installations), we recommend a distance of 1/2" (13mm) of free space above the housing.

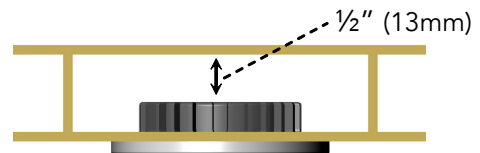

- 3 -

Installation Instructions (Recessed Mount)

1. Cut a circle in the mounting surface according to the cutout diameter required by your light (see chart on page 2).
2. Connect the light to a DC power source following the Wiring Instructions in the next section of this guide.
3. Once all electrical connections are made and secure, twist and remove the trim ring of your PowerLED and insert it into the cutout circle in the mounting surface. Fasten with #6 flat head screws (see Figure 1).
4. Place the trim ring/lens over the light making sure the tabs of the trim ring engage with the openings in the housing. Twist the trim ring on to secure it.

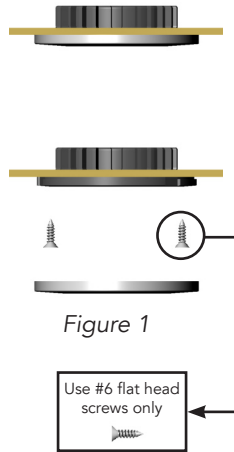

- 4 -

Installation Instructions (Surface Mount)

1. Connect the light to a DC power source following the Wiring Instructions in the next section of this guide.
2. Once all electrical connections are made and secure, twist and remove the trim ring of your PowerLED and insert it into the mounting base. Position the fixture in the desired mounting location and fasten with #6 flat head screws (see Figure 2).
3. Place the trim ring/lens over the light making sure the tabs of the trim ring engage with the openings in the housing. Twist the trim ring on to secure it.

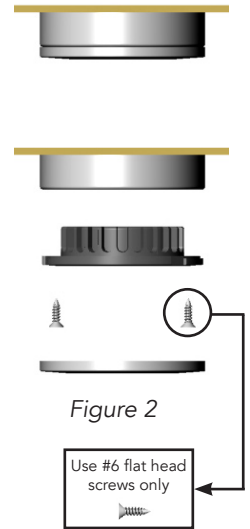

- 5 -

WIRING INSTRUCTIONS

1. Connect the light to a DC power source. Connect the red wire to positive DC voltage and the black wire to negative or ground.
2. If you will be dimming your PowerLED lighting, connect the white and grey wires to the white and grey wires of the PowerLED PWM Dimmer Module. You may connect as many as 30 PowerLEDs to the PowerLED Dimmer Module. Please refer to the PowerLED Dimmer Module Installation and Owner's manual for more information. *(Please see wiring diagram on p 10)*
3. If you will not be dimming your PowerLED lighting, simply trim the white and grey wires so that no bare conductor is exposed and cover the ends of the wires individually with insulation (shrink tube). *(Please see wiring diagram on p 8-9)*

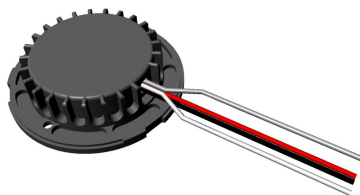

Wire	Function
Red	+ (white light)
Black	-
White	Dim +
Grey	Dim -

- 6 -

NOTES ON WIRE SIZE

The PowerLED family of products comes equipped with integrated driver electronics. These components are sensitive to DC systems with voltage drops. Therefore, it is imperative to select the correct wire size to supply DC voltage to the lights. This prevents excessive impedance and voltage drops which can cause premature failure in the PowerLEDs. It is recommended that the supply wire size be selected according to the ABYC Wiring Recommendations Chart for a 10% voltage drop. These charts can be found at www.imtra.com.

- 7 -

Wiring Diagram

- No Dimming
- Single Switch Location

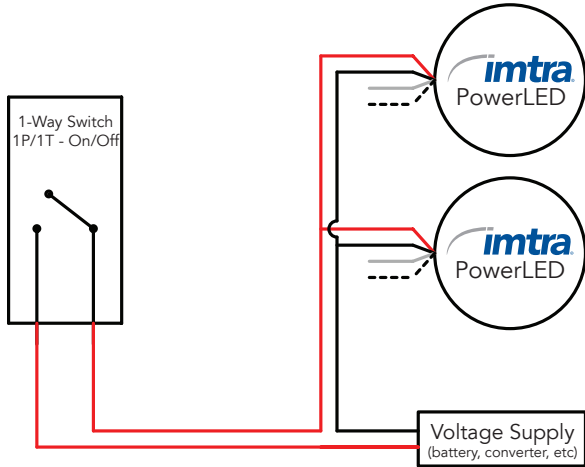

- 8 -

Wiring Diagram

- No Dimming
- Multiple Switch Location

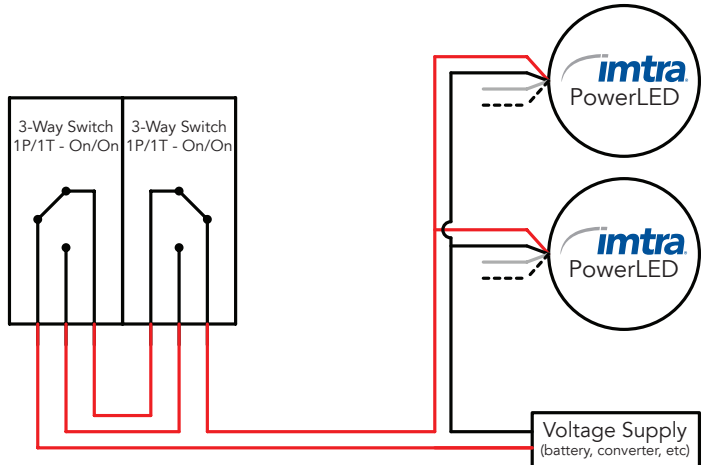

- 9 -

Wiring Diagram

- With Dimming

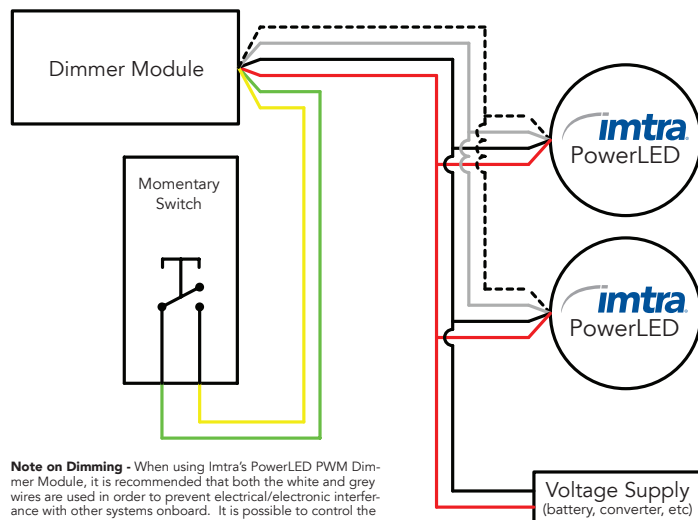

Note on Dimming - When using Imtra's PowerLED PWM Dimmer Module, it is recommended that both the white and grey wires are used in order to prevent electrical/electronic interference with other systems onboard. It is possible to control the PowerLED lights with the PowerLED PWM dimmer module via the white wire only by simply omitting the grey wire connections.

- 10 -

LIMITED WARRANTY

Imtra warrants the light-emitting LSA (LED spotlight assembly) component of our IML PowerLED spot lights & fixtures for 5 years from the date of purchase. If the LSA should cease to function within 5 years, return the complete spot light assembly to Imtra for repair or replacement.

This warranty does not apply to damage resulting from actions of the user such as misuse, improper wiring/installation, operation outside of specification, improper maintenance or repair, unauthorized modification, lightning strike or damage from a power surge.

The trim ring (bezel) of the IML Power LED spot lights are warranted for either two years (stainless steel or powder coated) or one year (gold or satin-nickel) depending on the finish of the fixture.

Imtra specifically disclaims any implied warranties, merchantability or fitness for a specific purpose and will not be liable for any direct, indirect, incidental or consequential damages. Imtra's total liability is limited to repair or replacement of the product.

The warranty set forth above is inclusive and no other warranty, whether written or oral, is expressed or implied.

If it should become necessary to return a fixture for service during or beyond the warranty period, please refer to Imtra's standard Return Policy as detailed on Imtra's website (www.imtra.com) or call Imtra customer service at (508) 995-7000.

No returns are accepted without a Return Authorization (RA) number.

- 11 -