



HR 2500 CHEETAH HORIZONTAL WINDLASS



Contents

Introduction	page 3
Important Information Safety	
Installation	page 4
Chain pipe Fitting	page 5
Manual Override System (MORS) Rope Chain Management System adjustment	
Depth of chain locker	page 6
Handy hints	page 7
Manual Operation Anchoring Retrieving chain Rope Hauling on Capstan	
Electrical information	page 7
Circuit breaker Deck switch Isolating switch Batteries Rotation	
Wiring layout	page 8
Operating Instructions	page 9
Servicing	
Maintenance Instructions	page 10
Rope/Chain splice Line care Trouble Shooting	page 11
Warranty and Warranty Registration Card	page 12
Deck Template	
Deck Template to suit all models	
Wiring Diagram	
All HR2500 Cheetah Models - 12/24V DC Three Wire 1200W motor	
Exploded View Drawings	
HR 2500 Single Gypsy / Capstan HR 2500 twin Gypsies Only HR 2500 Twin Gypsies and Capstans HR 2500 Single Gypsy / Capstan (left hand)	

INTRODUCTION

Thank you for purchasing a Muir Windlass. Muir go to great lengths to develop anchoring systems that not only meet all your performance and safety requirements, but at the same time are designed with a style and finish that enhances the aesthetics of your vessel. With Muir's commitment to quality and the use of superior materials and processes we know you will be pleased with your investment, and rest assured that through the correct installation, operation and maintenance your new Muir Windlass will give you years of reliable performance.

IMPORTANT INFORMATION

To avoid damage to the geardrive, windlass or vessel when bringing the anchor up hard, it is a preferred practice to mark the chain at approximately 5-meter intervals from the anchor, to alert the operator to the anchor position. Alternatively an Auto Anchor can be used.

Under no circumstances should the windlass be operated if it is stalled or overloaded.

If anchor retrieval is impaired by high wind, heavy seas or the anchor is snagged, ease the load by either motoring or sailing slowly forward into the wind with a chain stopping device in place. The rope or chain should be cleated off and the anchor driven out by the engine, otherwise the gearbox or shaft can be damaged.

SAFE OPERATION

- Ensure that hands, feet, hair and clothing are kept clear of the windlass and other loose gear when in operation.
- Ensure no one is swimming nearby when the anchor is being lowered or retrieved.
- Keep hands well clear of capstan, gypsy, chain and rope.
- The windlass should never be used for lifting people aloft.
- Do not use a windlass as a bollard for mooring, towing or being towed.
- When the windlass is at lay or the anchor stowed, always ensure the clutch is tightened with the clutch handle, and a Chain lock, Devils claw or Snubber Line is fitted to retain the anchor. The use of these accessories will prevent excessive loads on the geardrive and accidental release of the anchor.

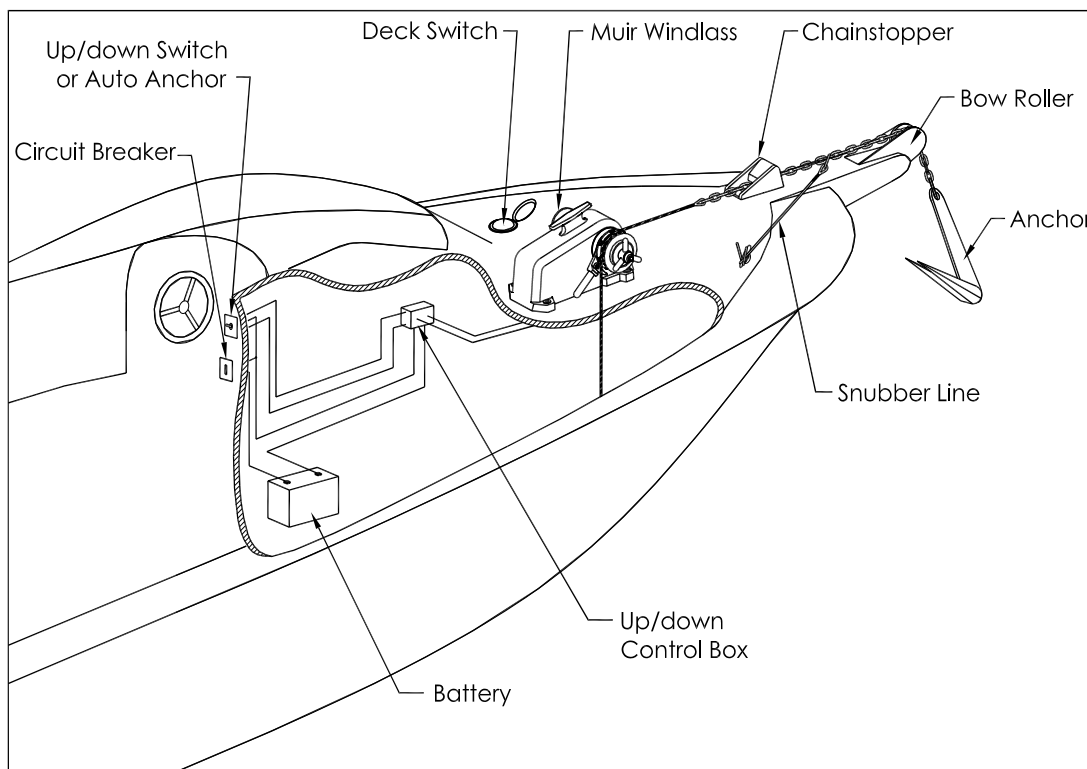

INSTALLATION

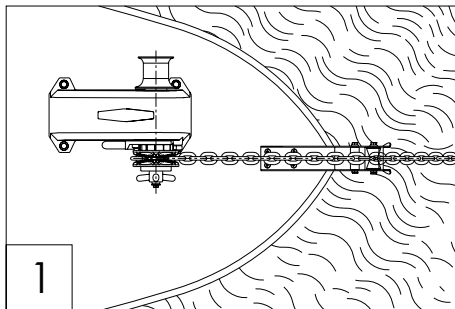

Figure(1)

Locate the windlass centrally fore and aft. Check that the chain leads unhindered to the anchor roller. The chain leads onto the top side of the starboard gypsy, wraps around 100° and falls below deck through the chain pipe (hawser). Ensure there is sufficient room around the windlass to allow full rotation of the windlass manual/clutch handle (if supplied).

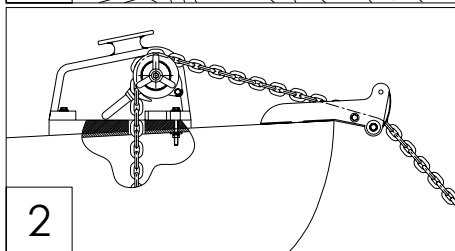

Figure (2)

The centre line of the gypsy must be in the same plane as the chain lead from the bow roller. If the deck is angled (fore & aft) or curved (port to starboard) a suitably shaped mounting block will be required to spread the load evenly over the deck surface and mount the windlass base on a level and even footing.

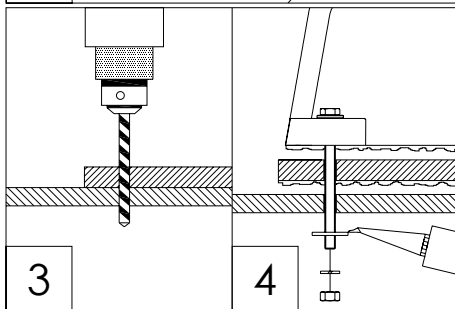

Figure (3)

Place the shaped mounting block (if required) onto the deck. Using the layout template supplied, mark the mounting centres and drill the holes 11mm (7/16") for the deck bolts of 10mm (3/8"). Mark the chain pipe centres at this time. (Refer template).

Figure (4)

Apply an appropriate sealant to the base plate and mounting block (if required) and carefully tighten the nuts & washers onto the deck bolts under the deck. Remove excess sealer. For Aluminium or Steel hull vessels, it is important to insulate the windlass with a non-conductive gasket to avoid corrosion. This also applies below deck with the mounting bolts, nuts and washers. Where the deck construction is light or of foam sandwich construction, a plywood stiffener of at least 16mm (5/8") should be fitted to the underside of the deck to spread the load and to prevent the bolts from pulling through the deck. Large diameter washers on the underside of the stiffener assists to spread the load.

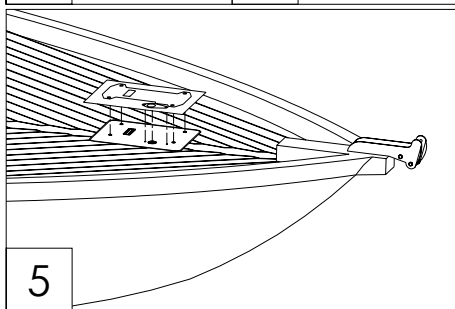

Figure (5)

1. Mount the windlass from above as shown.

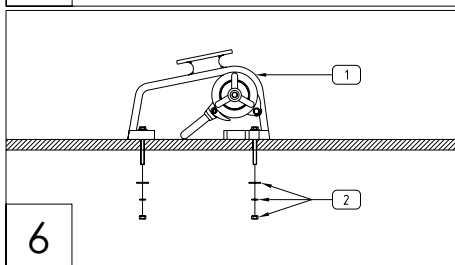

Figure (6)

2. From below, place washers and nut on each stud and tighten.

For fitting of the chain pipe or RCMS see next page

NOTE: On assembly, grease all moving parts with a Lithium/teflon based grease.

Horizontal Winch Chain pipe Fitting

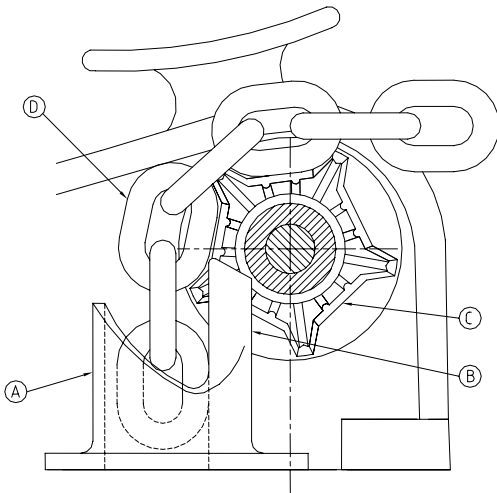

1. To position the chain pipe (A), first align the stripper (B) with the centre of the gypsy.
2. Wrap the chain (D) around the gypsy (C) and through the chain pipe to position the chain pipe correctly.
3. Align the stripper to the inside of the chain as it falls vertically into the chain locker.
4. Mark the chain pipe position and drill the bolt holes, finally cut out the section for the chain to pass through the deck and then bolt the chain pipe into place.

Horizontal Winch Chain pipe with Rope/Chain Management System Fitting

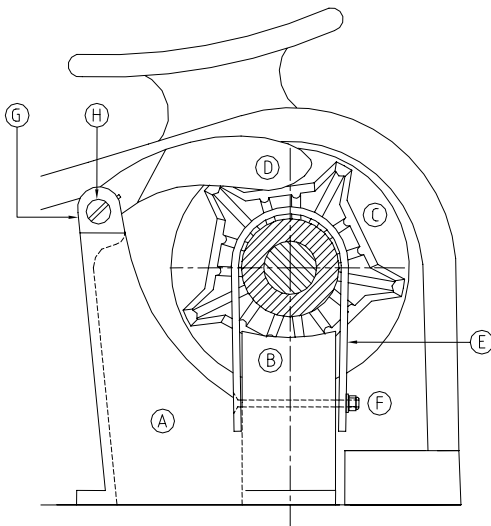

1. Position the chain pipe (A) so that the peeler (B) is directly under the centre of the gypsy (C), and the finger sits on top (D).
2. Slide the S/S stripper (E), over the middle of the gypsy lining it up with the hole in the peeler for the screw (F).
3. Fit the stripper with the screw making sure the countersunk head is inside the chain pipe. Tighten with washer and nylock nut
4. Check the position of the chain pipe and make sure the stripper does not hit the gypsy when it is rotating. Spot the holes for the chain pipe on the deck with the chain pipe in position. Remove the chain pipe and drill the mounting holes. Refit the chain pipe, checking its position again, and fasten it to the deck.
5. To tension the rope finger, loosen the grub screw (G), behind the finger in the chain pipe, and turn the pin (H), towards the gypsy with a large screwdriver.

Manual Override System (MORS)

This allows the operator to manually recover the anchor and anchor rode without the use of the electrics. For manual operation the locking pawl should be first engaged into the gypsy, this stops the gypsy from running back wards, the clutch should be released marginally by turning in an anti-clockwise direction. Now the gypsy is free to turn and the manual override handle can be moved in a clockwise direction to engage the gypsy, when pulling in an anti-clockwise direction the MOR pawl will engage and drive the gypsy retrieving the chain, as the handle is moved clockwise the weight will be taken by the locking pawl.

Rope/Chain Management System (RCMS)

Optional chain pipe kits (with pipe, special 180 degree stripper and spring loaded finger are available. The rope finger pawl guides the rope and chain around the gypsy and through this special chain pipe.

The standard chain pipe with its integral stripper is normally supplied when otherwise specified or ordered by the customer.

Adjustment: Firm tension of the finger is required to reduce rope (nylon Line) slipping through the gypsy. Check the spring tension (at least) annually and re-tension the spring when needed. To adjust this tension (if your line is slipping) refer to the procedure below.

Procedure:

1. Loosen the grub screw on the chain pipe with an Allen key for finger adjustment.
2. Turn the screwdriver clockwise to tension the spring, while holding the tension re-tighten the grub screw

DEPTH OF THE CHAIN LOCKER

Measuring the vertical distance (minimum fall) underside of the deck and the top of the completely stored and heaped anchor rode in the locker will assist in determining the installation to suit your vessel. Refer to the fall depth diagrams to the left, and the options detailed below. It is also recommended that the chain be directed to the center of the chain locker.

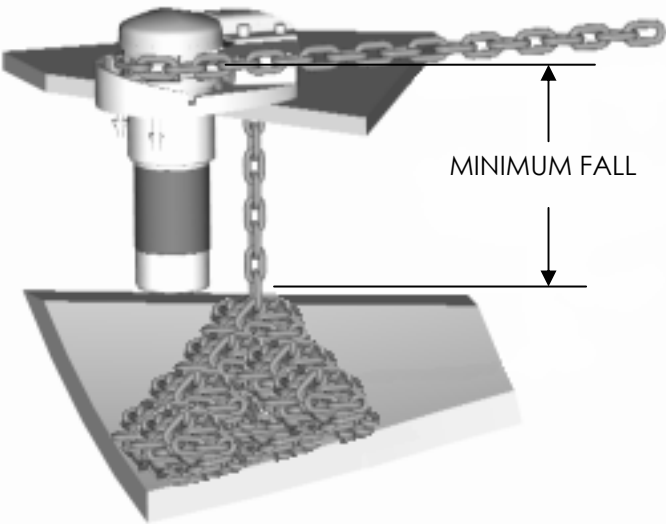

Vertical Windlass:

The running gear, gypsy and capstan are positioned above the deck with the motor and gear drive below. Vertical windlasses operate at best with greater anchor rode fall than the horizontal windlass and a minimum fall of 300mm from top of stacked anchor rode is recommended. This is particularly important if using nylon line, which does not fold and stack as well as chain. Vertical windlasses minimise deck intrusion and the modern curved lines of the Muir windlass enhance the look of any vessel. A vertical windlass provides the advantages of a 180-degree wrap of the anchor rode around the gypsy.

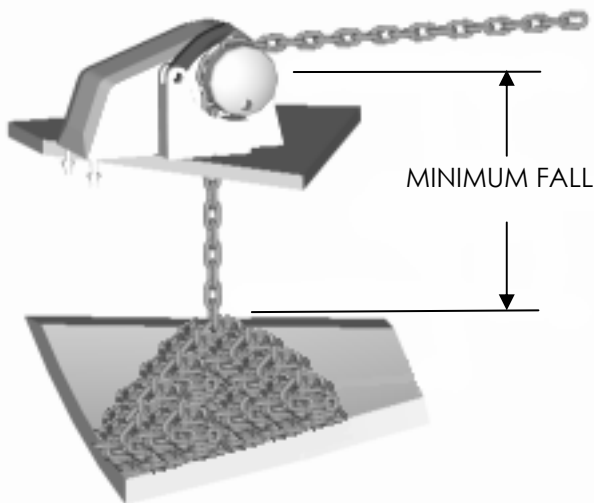

Horizontal Windlass:

Fully enclosed, above deck, this style is usually preferred where locker space is limited or additional fall is required. The motor and gear drive is fully enclosed in the housing with nothing protruding below deck. The horizontal windlass operates with optimum anchor rode fall of at least 300mm from the top of the stacked anchor rode, and due to the horizontal orientation of the gypsy higher above the deck there is additional fall provided. These units are ideally suited for vessels with less locker space.

Vertical Windlass Model	Horizontal Windlass Model	Minimum Fall (Dist. Top of Pile)
VR/C 600	HR 600 / 700 / 806 / 808	300 mm
VR/C 850 / 1250 / 2200	HR 1200	450 mm
VR/C 2500 / 3500	HR 2500 / 3500	650 mm
VR/C 4000	HR 4000/- 4200	800 mm

HANDY HINTS

It is a common mistake to locate the windlass too far forward, or too close to the bulk head, where there is insufficient room for chain and anchor stowing. The chain fail position should be in the centre of the chain locker. If the chain falls alongside a bulkhead or onto the stem it will pyramid and jam.

If the chain falls into an undesirable position, a metal tube can be fitted under the hawser to redirect the chain to a preferred position. This pipe should be at least 1 ½ times the width of the chain. It should also have as much vertical angle as possible. Position the windlass in the best location with the chain hawser facing forward. Ensure sufficient room to run electric cables to the windlass. Follow the instructions on page 4 including underdeck stiffening, deck camber, alignment, mounting blocks and sealing procedures.

ELECTRICAL

See Wiring Diagrams for wiring instructions.

Circuit breaker (must be fitted to ensure warranty)

If the windlass is overloaded or stalled the circuit breaker automatically cuts off power to the windlass and protects the wiring and motor. The circuit breaker should not be used as an isolating switch, purely for safety reasons.

Deck Switches are best located out to either port or starboard or directly behind the windlass in a position where it can be easily reached with your foot or knee, preferably where you can view the anchor and chain coming aboard.

Isolating Switch should be fitted in an accessible position for safety, ideally close to the battery or switches. The isolating switch is not a circuit breaker.

Batteries are best located as close to the windlass as possible. Larger cables will reduce the voltage drop to the motor and the heat generated when running the windlass. Small diameter cables drop voltage considerably. Use the following table as a guide to your required wire size:

Distance from battery to motor (m)	Cable Size		Cable Diameter (mm)
	(mm ²)	AWG	
7 (23')	25	3	8 (5/16")
9 – 17 (30' – 55')	50	1/0	10 (3/8")

Rotation: Windlasses may be wired for single or dual direction, using single or dual deck switches for raising or lowering. Alternatively a remote control solenoid packages with Toggle Switch, Hand Pendant or Auto Anchors are available.

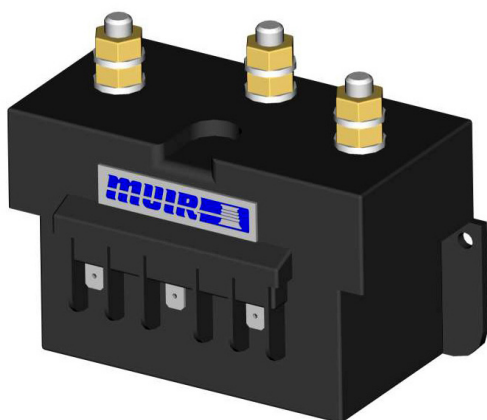

Solenoid Installation

We recommend that the solenoid is installed in an upright position, where it has minimal exposure to sea water and in close proximity to the electric motor of the windlass.

For wiring information, please refer to the appropriate wiring diagram.

WINCH MODEL	MOTOR SIZE	MOTOR TYPE
HR 2500	1200 W	3 POLE

For wiring information, please refer to the appropriate wiring diagram.

TOGGLE SWITCH LAYOUT

1. BATTERY
2. CIRCUIT BREAKER
3. SOLENOID/CONTROL BOX
4. TOGGLE SWITCH

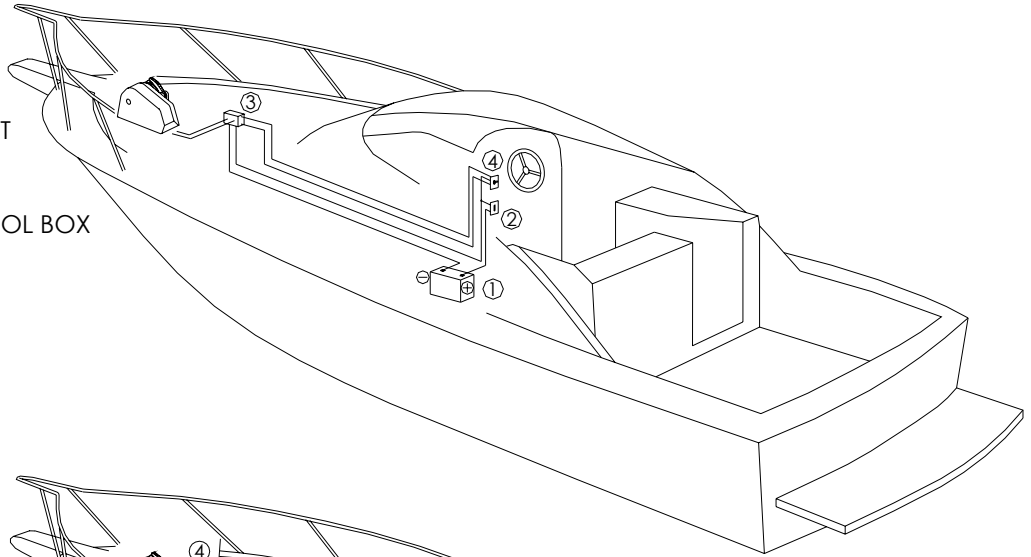

TOGGLE / DECK SWITCH LAYOUT

1. BATTERY
2. CIRCUIT BREAKER
3. SOLENOID/CONTROL BOX
4. DECK SWITCHES
5. TOGGLE SWITCH

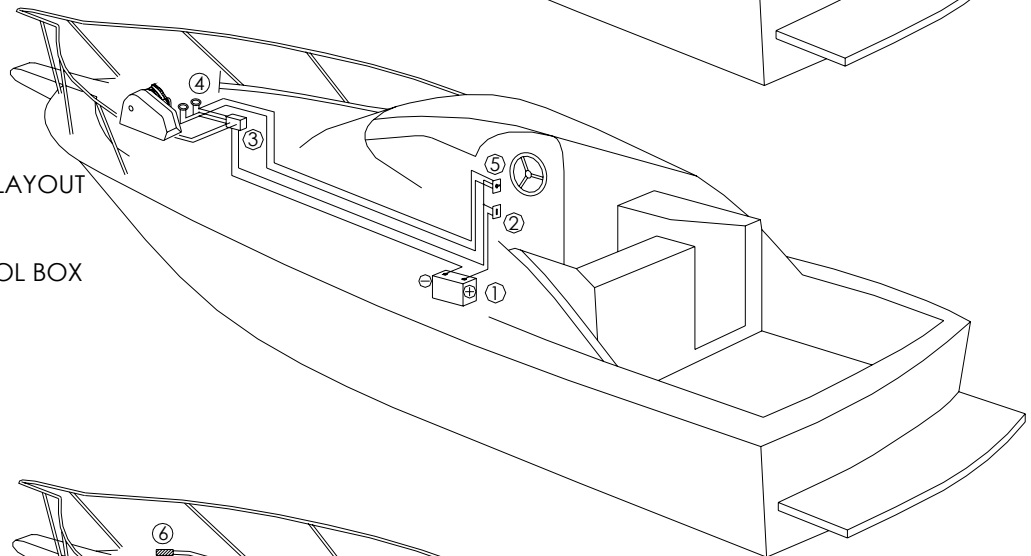

AUTO ANCHOR LAYOUT

1. BATTERY
2. CIRCUIT BREAKER
3. SOLENOID/CONTROL BOX
4. DECK SWITCHES
5. AUTO ANCHOR
6. AUTO ANCHOR SENSOR

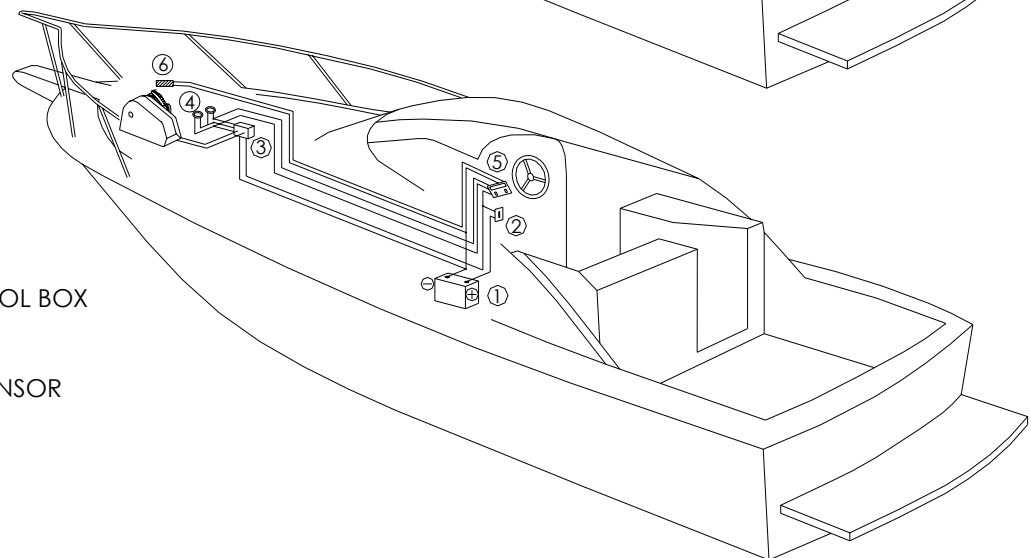

NOT TO BE USED AS WIRING DIAGRAMS

OPERATING INSTRUCTIONS

Manually Releasing chain: To release the anchor rode, place the handle onto the clutch nut as shown in the diagram at the bottom of the page and turn **anti-clockwise** to release the clutch brake. Let the anchor fall and control the run of the chain by tightening handle **clockwise** using the clutch mechanism as a brake.

Anchoring: When laying at anchor use a chain stopper, nylon/chain bridle or snubber line to prevent snatching and direct load on the windlass main shaft. Never use the windlass as a mooring bollard!!

Retrieving Chain: Before operating the windlass tighten the clutch with the handle in a **clockwise** direction, then remove the handle. If the anchor is buried hard, motor forward to pull it free after hardening up on the windlass, to ease the load on the windlass.

Rope Hauling on the Capstan: The capstan can be operated independantly of the gypsy. Secure the anchor rode (via Chainlock, Gypsy lock or Snubber) then release the clutch. The windlass capstan can now be operated separately.

Electric / Hydraulic operation: Releasing or retrieving the Anchor rode is identical when operating a Hydraulic or Electric windlass. To release the anchor down reverse the motor by pushing remote switch to "down" which drops the chain and the anchor immediately. When the anchor is at the desired depth, the windlass can be stopped by letting go of the switch, the chain and rope can then be lowered further by releasing the manual clutch. Always keep well clear of the windlass when releasing or retrieving the chain and anchor. Keep fingers, hair and clothing well clear when the windlass is in operation.

Auto Anchor Launching: Two direction windlasses are now standard. If the anchor and anchor roller can be positioned so that it falls as soon as the windlass is reversed, the whole operation can then be carried out remotely from aft or fly bridge. Remote switch controls are self-centering and stop the windlass when the switch is released. Mark the anchor end of the chain at 2 and 5 metre (6.5' & 16.5') intervals which will enable the operator to judge when the anchor is almost up. Go gently with the last two metres of retrieving the anchor by letting go of the switch, rather than waiting for the anchor to fly up over the roller and bang tight, putting excessive load onto the bow roller, windlass and fore deck.

SERVICING

The geardrive is filled and sealed at factory with long life synthetic oil and does not require replacement. A rinse of fresh water on all your deck gear after every excursion ensures all salt deposits and corrosion are kept to a minimum.

Regularly clean the clutch cones and re-apply a thin film of water proof grease to the cone surfaces. This ensures smooth running of the gypsy and chain when the manual freefall is operated.

We recommend the windlasses of Pleasure Vessels are stripped yearly and all moving parts cleaned and greased with a Marine Grease, Teflon or Lithium based grease (e.g. Duckhams'Keenol'; 'Castrol LMX'.). In the case of Work and Charter Vesels we suggest it is carried out more frequently. **Do not use soap based grease.**

Manually Releasing chain

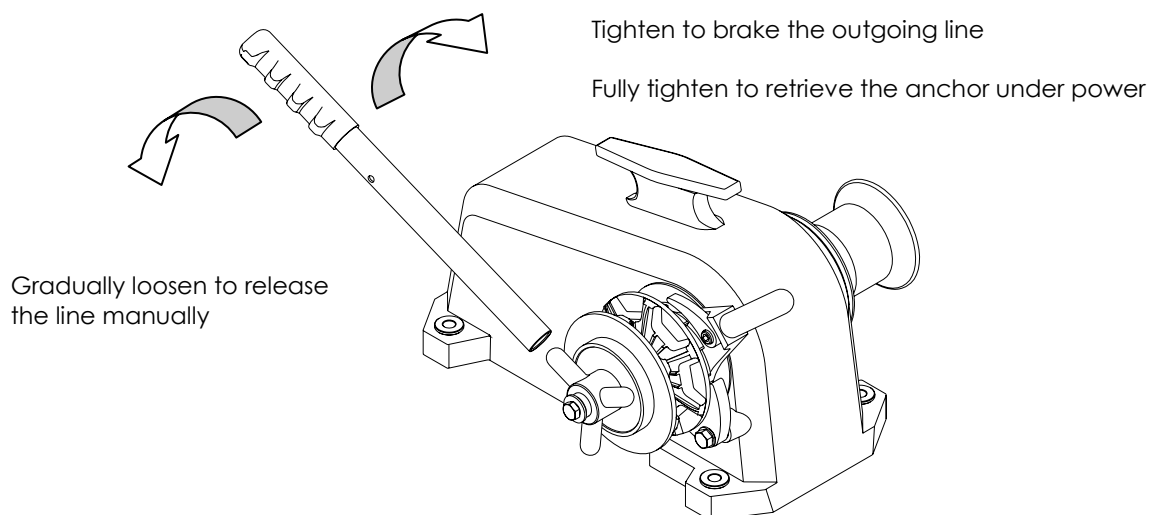

MAINTENANCE INSTRUCTIONS

You will require the following tools to complete this procedure:

- (i) Clutch/Manual recovery handle
- (ii) 14mm(9/16") Socket & 3" extension bar with ratchet.
- (iii) A Lithium/Teflon based marine grease.
- (iv) HR 2500 Exploded view Dwg: K08-COMHR2500

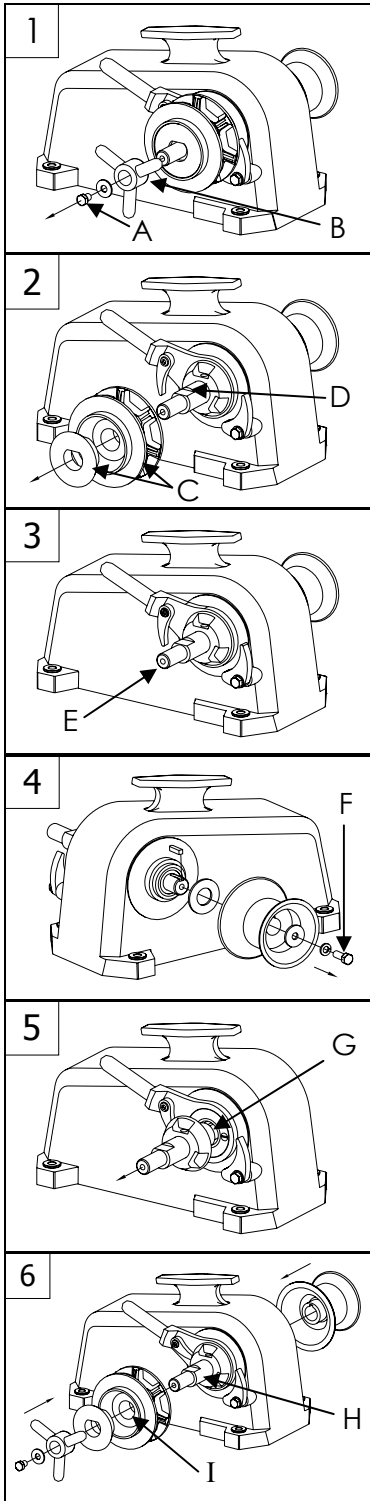

1. Removing Clutch Nut

& Hex head Screw. Place 14mm (9/16") Socket onto (A) Screw and turn anti-clockwise to remove. Now the Clutch nut (B) can be removed by turning it anti-clockwise (this may require the initial use of the Clutch/Manual recovery handle).

2. Removing Gypsy

& D-cone The D-cone & Gypsy (C) are now free to remove from the Main Shaft (D).

3. Greasing (if no further maintenance is required)

After removing the gypsy & D-cone it is now possible to grease the exposed Main shaft & cone (E). Then reverse the above steps to re assemble. (Also see Note on bottom of page)

4. Removing Capstan.

Place 14mm(9/16") Socket onto (F) Screw and turn anti-clockwise to remove. Now the Capstan can be removed. Taking Care not to lose the capstan drive key.

5. Greasing

Slide Shaft out partly as shown, then generously grease (G) the surface/bore of bush and exposed Main Shaft

6. Re-assembly

Before re-assembly, grease the exposed Main Shaft/cone (H) & Gypsy bore (I). To complete the service or replacement of parts reverse the above steps.

Note:

- We recommend the use of Lithium/Teflon based grease.
- We also recommend that the windlass be serviced at least yearly.

In the case of Work/Charter Vessels the windlass may require a more regular servicing

Rope/Chain Splice.

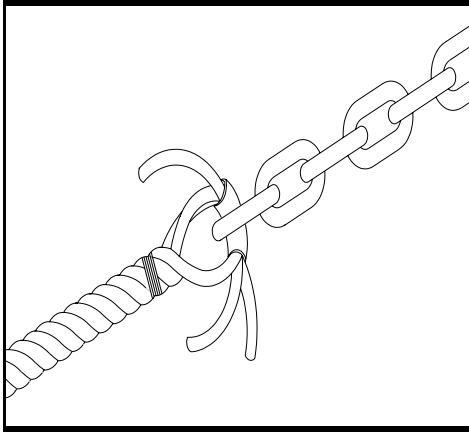

1. To stop rope unravelling, seize rope 400mm (16") from end with whipping twine. Unlay strands.
2. After placing 20mm (3/4") of heat shrink sleeve tubing through the last link of chain, pass one strand of rope through sleeve and chain from one side and the other two strands of rope from the opposite side. (See illustration).
3. While pulling all three strands tight, shrink the sleeve tightly onto the rope using a hairdryer / fan heater or by immersing in boiling water.
4. Remove seizing and complete back splice in normal manner for two full tucks. With a hot knife pare down the three strands by 1/3 and insert two further tucks. Pare down by another 1/3 and finish with two tucks. Cut any remaining tails.

Line Care

Using the wrong type of line may cause the line to jam causing excessive line wear. Muir Windlasses are designed to run on 3-strand nylon line (supplied by Muir) which has been specially treated with fabric softener to prevent it from hardening. It is recommended to soak your rope in fresh water containing fabric softener every 3 months.

In case of a rope jam, slacken off the windlass clutch to free the jammed line. When retrieving the anchor rode do not continue to run the windlass if the anchor or chain is jammed, as line slippage in the gypsy will cause damage to the line.

Trouble Shooting

ELECTRICAL

1. Check the battery circuit breaker and ensure the isolating switch is on.
2. Check battery is charged up to 12 or 24 volts.
3. Check that the foot switch plunger is contacting
4. Check remote control solenoid is contacting, if this is clicking the problem may be low voltage, a faulty solenoid or a wire not properly connected.
5. Check wiring between controls, solenoid and motor are in-tact.
6. If the motor will not turn after checking the above points, check that the motor bushes are not worn or sticking.

MECHANICAL

If the windlass running gear will not turn or operate check the following

1. Check that the clutch beside the chain gypsy is tightened to the chain gypsy drive using the manual handle supplied (see operating instructions).
2. If the line slips check the tension on the finger and increase spring tension (see RCMS adjustment on this page).

HYDRAULIC MOTOR

Refer any problems with your hydraulic motor to a Muir service agent or Muir Hobart.

Warranty
Limited for period of Three years (First Owner)

We warrant each new product manufactured by us to be free from defects in material and workmanship for a period of 3 years (first Owner).

This warranty shall become effective only upon receipt of a completed warranty registration, which shall identify the product so registered by serial number. This warranty shall remain in effect for a period of three (3) years from the date of purchase. For vessels in charter or hire the warranty is one (1) year due to various operators and overloading which may occur.

Conditions

While this warranty applies to defects in material and workmanship, it does not apply to:

- Normal worn parts or to damage caused by neglect, lack of maintenance, accident or improper service/installation or service by persons other than an authorised Muir representative.
- Muir shall not be responsible for failures due to products being used in applications that they are not intended for, or exceed the products performance specifications.
- For warranty claim, defective product must be returned to Muir for inspection.
- Muir will not be responsible for freight charges, removal or installation labour on warranty claims.
- Damage due to unsatisfactory storage or use of equipment prior to installation in the approved/intended manner.

Exclusions

Warranty is limited to twelve months for:

- Electric motors / controls / equipment
- Hydraulic pumps / controls / valves
- Weather seals
- Use on charter/hire/commercial boats

All incidental and/or consequential damages are excluded from this warranty. Warranties of merchantability and fitness are excluded from this warranty. Implied warranties are limited to the life of this warranty. Some countries do not allow limitations on how long an implied warranty lasts or the exclusion or limitation of incidental or consequential damages, so the above may not apply to you.

We reserve the right to improve the design or materials used on any product without assuming any obligation to modify any product previously manufactured or used.

Liability

Muir Engineering liability under this warranty shall be to the exclusion of all other warranties or liabilities (to the extent permitted bylaw). In particular (but without limitation):

Muir Engineering shall not be liable for:

Any indirect or consequential loss including (without limitation) any loss of anticipated profits, damage to reputation or goodwill, loss of expected future business, damages, costs or expenses payable to any third party or any other indirect losses. Any damage to yachts or equipment. Death or personal Injury (unless caused by Muir Engineering negligence).

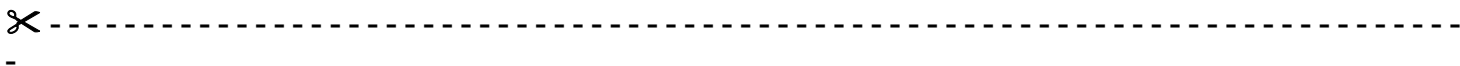

WARRANTY REGISTRATION CARD

Return To

MUIR ENGINEERING PTY. LTD.
 100 Browns Rd, Kingston
 Tasmania, Australia, 7050

**WARRANTY VOID UNLESS CIRCUIT
 BREAKER OR RELIEF VALVE FITTED**

Customer Name :	Address / Contact :
Winch Model :	Serial No :
Date of Purchase :	
Supplier Name :	Address :

NORMALLY APPLIES TO THESE WINCHES AND MOTORS

MOTOR 12/24V	1000W	1200W	1500W
WINCH MODEL	COUGAR	CHEETAH	JAGUAR
	V 1000	V 1200	THOR
	V 1050	V 2200	V 3500
	V 1250	V 2500	

CHAIN METER
P/N: F80-CMAA500C
REFER TO MANUAL FOR
INSTALLATION GUIDELINES



SENSOR MOUNTED UNDER
GYPSY (CHAIN WHEEL)
P/N: F80-CMSENSOR

YELLOW (DOWN)
ORANGE (UP)
BLACK NEG -

RED POS +

HAND PENDANT
P/N: F80-HP02

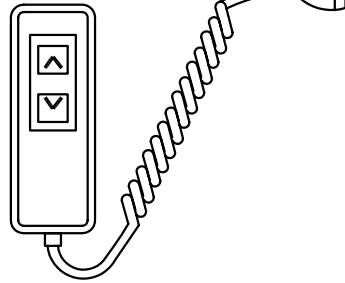

SOCKET

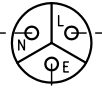

WARNING:
DO NOT ACTIVATE ANY UP & DOWN
SWITCH AT THE SAME TIME. REFER TO
MANUAL FOR MORE INFORMATION

DECK SWITCHES
P/N: F80-DS

DOWN UP

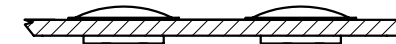

TOGGLE SWITCH
P/N: R80-TS3P

DOWN

UP

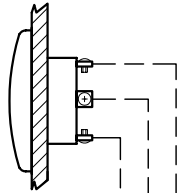

CIRCUIT BREAKER
P/N: F80-CB

3A CIRCUIT
BREAKER

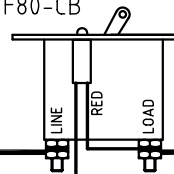

CONTROL BOX
P/N: F80-RS

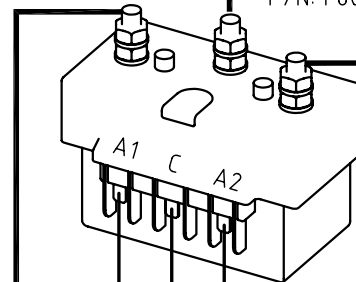

ISOLATING
SWITCH



BLACK

BATTERY

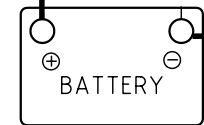

WINCH
MOTOR

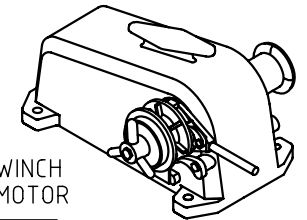

F1
A2
F2

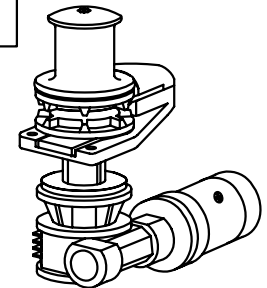

- REFER TO MANUAL FOR WIRING INDICATED BY HEAVY LINES
- LIGHTER LINES INDICATE LIGHT WIRING.
- - -** DASHED LINES INDICATE OPTIONAL WIRING.

TOLERANCES (mm)

- X. ±
- X.X ±
- X.XX ±

UNLESS OTHERWISE SPECIFIED

MATERIAL

FINISH



WINDLASSES AUSTRALIA

TITLE
**THREE TERMINAL MOTOR (REVERSING)
WIRING DIAGRAM (POSITIVE ACTING SOLENOID)**

PART No.

DRN JK	DATE 25/11/02	DRG No. WIRE1075
SCALE NTS	APP1	APP2
		SIZE A4

© COPYRIGHT MUIR ENGINEERING PTY. LTD.

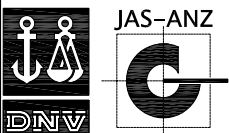

DNV Certification Pty Ltd
Quality Assured ISO9001:2000

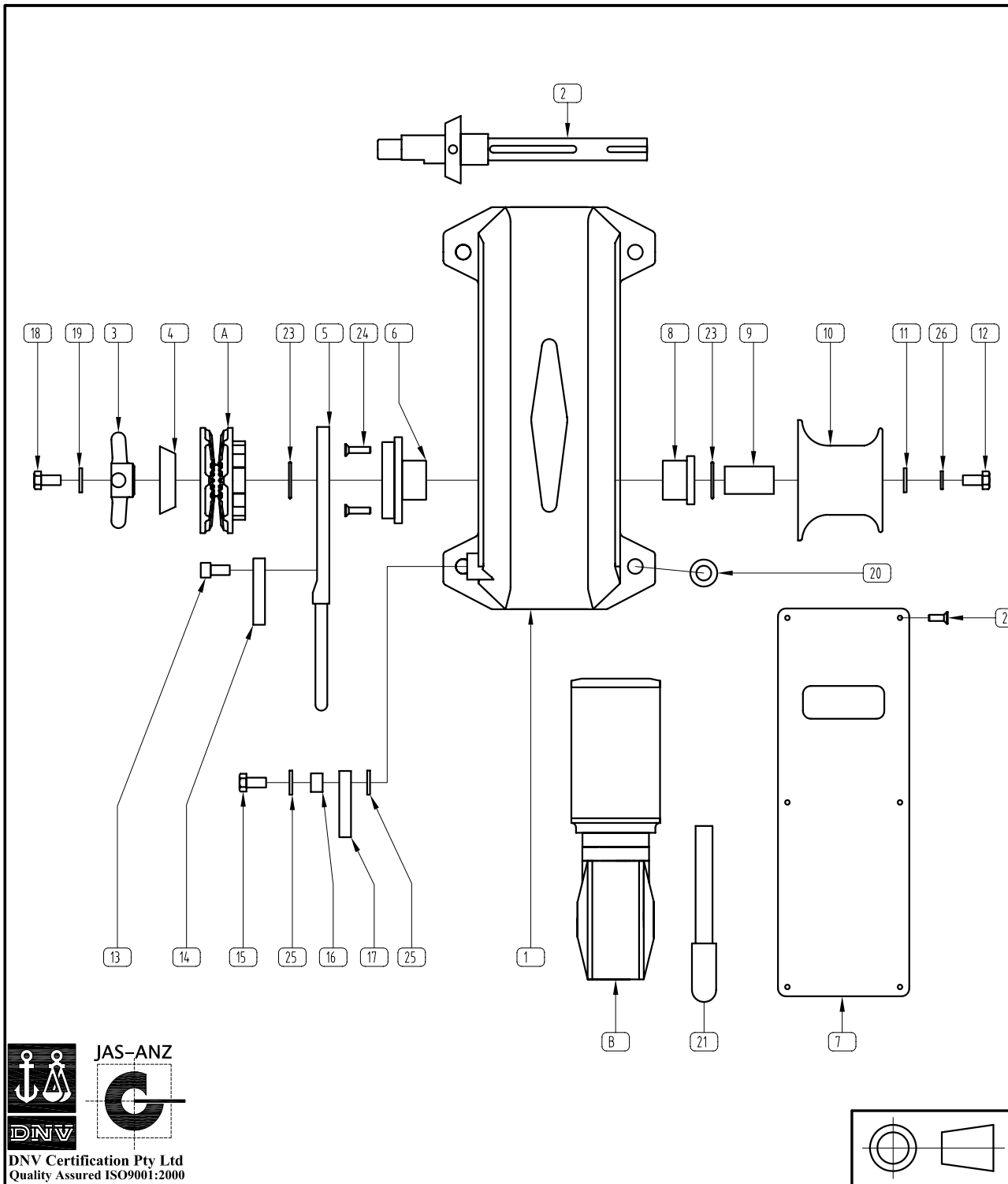

ITEM	PART NUMBER	DESCRIPTION	QTY
1	P22-HSGHR2500A	HOUSING ALLOY HR2500 CHEETAH SG/SC	1
2	K06-SFTHR2500A	SHAFT ASSEMBLY HR2500 CHEETAH SG/SC	1
3	P07-CLNBRZHR01200C	CLUTCH NUT BRONZE HR1200 COUGAR 3 PRONG	1
4	P08-CNEBRZHR01200CD	'D' CONE BRONZE HR1200C COUGAR	1
5	P11-HANAB2LEV01200C	HANDLE LEVER AB2 HR1200C COUGAR	1
6	P02-NOVHR01200CLH	BEARING LEVER HANDLE NOV HR1200C COUGAR	1
7	P22-BPLALLHR02500	BASE PLATE ALLOY HR2500 CHEETAH	1
8	P02-NOVHR01200CCS	BEARING CAPSTAN SIDE NOV HR1200C COUGAR	1
9	P02-GSH035.0025.052	SPACER GUARDSHAFT HR1200C CAPSTAN	1
10	P04-CAPBRZ01200C	CAPSTAN BRONZE HR1200C COUGAR	1
11	P21-BRS031.8009.503	WASHER BRASS 1-1/4" X 3/8" X 3MM	1
12	S36-30409.52025	SCREW HEX HD SS304 3/8 INCH X 1 INCH	1
13	S45-30407.94013	SCREW SHCS SS304 5/16 X 0-1/2 INCH	1
14	P13-BRZLEVHR1200C	PAWL LEVER HANDLE HR1200C COUGAR	1
15	S13-30409.52038	BOLT HEX HD SS304 0-3/8 X 1-1/2 INCH	1
16	P02-303013.5009.314	BUSH SS303 HR1200C COUNTERWEIGHT PAWL	1
17	P13-BRZCWGHR1200C	PAWL COUNTERWEIGHT HR1200C COUGAR	1
18	S36-30409.52013	SCREW HEX HD SS304 3/8 X 0-1/2 INCH	1
19	S75-30409.52025	WASHER FLAT SS304 3/8 INCH 1 LGE/OD	1
20	P02-NYL025.0010.517	BUSH NYLON HR1200C COUGAR FOOT	4
21	P11-HAN304EXHR1200C	HANDLE EXTENSION 304 HR1200C COUGAR	1
22	S33-30404.76013	SCREW CSK SL MT 304 0-3/16 X 0-1/2 INCH	6
23	R41-ORG04203503.5	'O' RING SEAL 42X35X3.5 (BS220)	2
24	S33-30406.35025	SCREW CSK SL MT 304 0-1/4 X 1 INCH	2
25	S75-30409.52019	WASHER FLAT SS304 3/8 INCH X 0-3/4 INCH	2
26	S76-30409.52	WASHER SPRING SS304 3/8 INCH	1

A: GYPSY
 B: MOTOR / GEARBOX ASSEMBLY

MUIR WINDLASSES AUSTRALIA

TITLE
 HR2500 COMPACT / SINGLE GYPSY/CAPSTAN
 EXPLODED VIEW / CAPSTAN TO PORT

PART No.
 K08-COMHR2500 (CHEETAH)

DRN AC	DATE 07/04/02	DRG No. K08-COMHR2500
SCALE NTS	APP1	APP2
FINISH		SIZE A4

© COPYRIGHT MUIR ENGINEERING PTY. LTD.

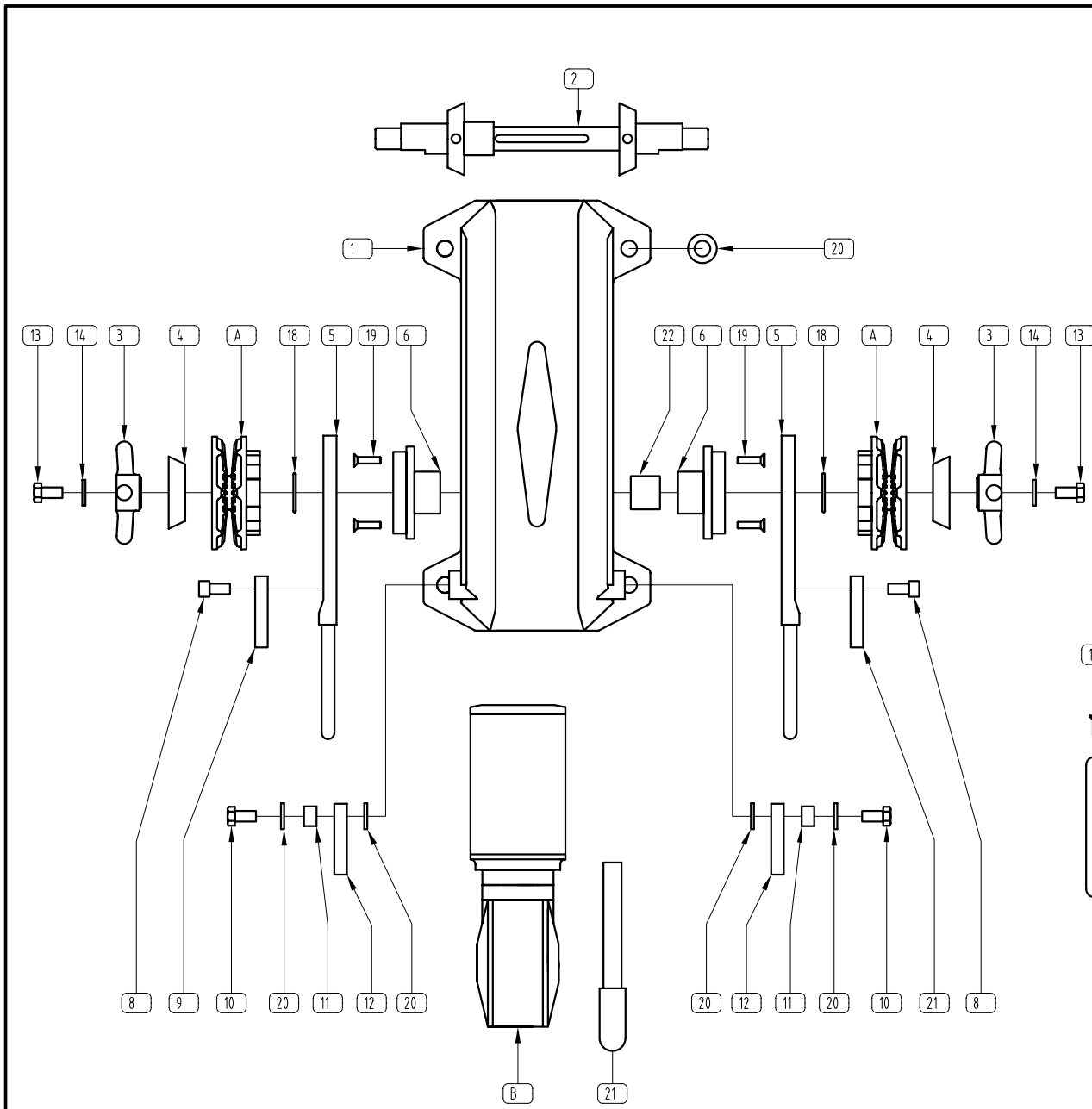

ITEM	PART NUMBER	DESCRIPTION	QTY
1	P22-HSGHR2500ATG	HOUSING ALLOY HR2500 CHEETAH TWIN GYPSY	1
2	K06-SFTHR2500B	SHAFT ASSEMBLY HR2500 CHEETAH TG	1
3	P07-CLNBRZHR01200C	CLUTCH NUT BRONZE HR1200 COUGAR 3 PRONG	2
4	P08-CNEBRZHR01200CD	'D' CONE BRONZE HR1200C COUGAR	2
5	P11-HANAB2LEV01200C	HANDLE LEVER AB2 HR1200C COUGAR	2
6	P02-NOVHR01200CLH	BEARING LEVER HANDLE NOV HR1200C COUGAR	2
7	P22-BPLALLHR02500	BASE PLATE ALLOY HR2500 CHEETAH	1
8	S45-30407.94013	SCREW SHCS SS304 5/16 X 0-1/2 INCH	2
9	P13-BRZLEVHR1200C	PAWL LEVER HANDLE HR1200C COUGAR	1
10	S13-30409.52038	BOLT HEX HD SS304 0-3/8 X 1-1/2 INCH	2
11	P02-303013.5009.314	BUSH SS303 HR1200C COUNTERWEIGHT PAWL	2
12	P13-BRZCWGHR1200C	PAWL COUNTERWEIGHT HR1200C COUGAR	2
13	S36-30409.52013	SCREW HEX HD SS304 3/8 X 0-1/2 INCH	2
14	S75-30409.52025	WASHER FLAT SS304 3/8 INCH 1 LGE/OD	2
15	P02-NYL025.0010.517	BUSH NYLON HR1200C COUGAR FOOT	4
16	P11-HAN304EXHR1200C	HANDLE EXTENSION 304 HR1200C COUGAR	1
17	S33-30404.76013	SCREW CSK SL MT 304 0-3/16 X 0-1/2 INCH	6
18	R41-ORG04203503.5	'O' RING SEAL 42X35X3.5 (BS220)	2
19	S33-30406.35025	SCREW CSK SL MT 304 0-1/4 X 1 INCH	4
20	S75-30409.52019	WASHER FLAT SS304 3/8 INCH X 0-3/4 INCH	4
21	P13-BRZLEVHR1200CL	PAWL LEVER HANDLE HR1200C COUGAR LH	1
22	P02-GSH035.0025.052	SPACER GUARDSHAFT HR1200C CAPSTAN	1

MUIR WINDLASSES AUSTRALIA

TOLERANCES (mm)			
X.	±		
X.X	±		
X.XX	±		
UNLESS OTHERWISE SPECIFIED			
MATERIAL		DRN	DATE
		AC	07/04/02
FINISH		DRG No.	DRG No.
			K08-COMHR2500B
SCALE	APP1	APP2	SIZE
NTS			A4
© COPYRIGHT MUIR ENGINEERING PTY. LTD.			

JAS-ANZ

 DNV Certification Pty Ltd
 Quality Assured ISO9001:2000

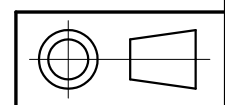

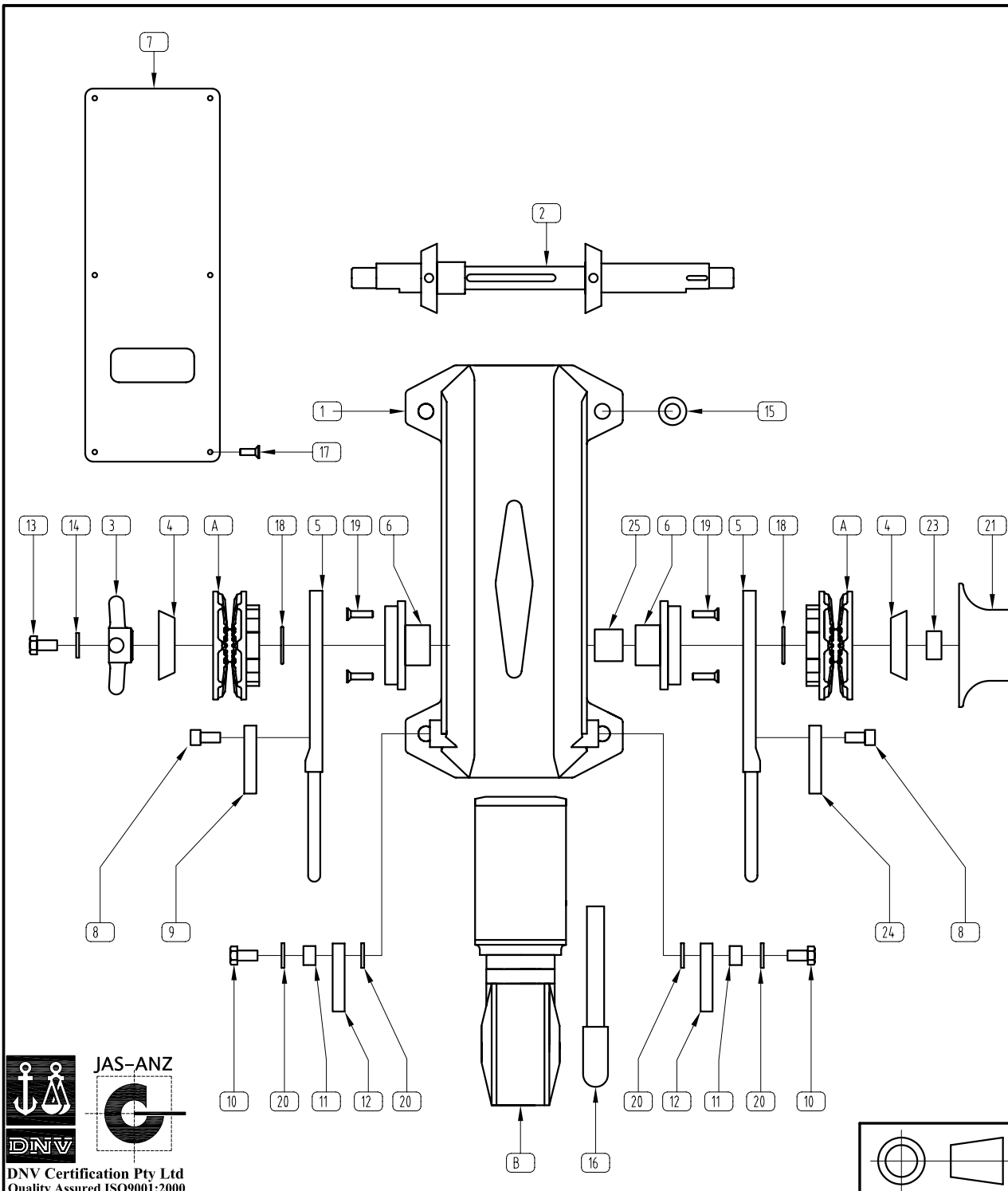

ITEM	PART NUMBER	DESCRIPTION	QTY
1	P22-HSGHR2500A	HOUSING ALLOY HR2500 CHEETAH SG/SC	1
2	K06-SFTHR2500C	SHAFT ASSEMBLY HR2500 CHEETAH TG/SC	1
3	P07-CLNBRZHR01200C	CLUTCH NUT BRONZE HR1200 COUGAR 3 PRONG	2
4	P08-CNEBRZHR01200CD	'D' CONE BRONZE HR1200C COUGAR	2
5	P11-HANAB2LEV01200C	HANDLE LEVER AB2 HR1200C COUGAR	2
6	P02-NOVHR01200CLH	BEARING LEVER HANDLE NOV HR1200C COUGAR	2
7	P22-BPLALLHR02500	BASE PLATE ALLOY HR2500 CHEETAH	1
8	S45-30407.94013	SCREW SHCS SS304 5/16 X 0-1/2 INCH	2
9	P13-BRZLEVHR1200C	PAWL LEVER HANDLE HR1200C COUGAR	1
10	S13-30409.52038	BOLT HEX HD SS304 0-3/8 X 1-1/2 INCH	2
11	P02-303013.5009.314	BUSH SS303 HR1200C COUNTERWEIGHT PAWL	2
12	P13-BRZCWGHR1200C	PAWL COUNTERWEIGHT HR1200C COUGAR	2
13	S36-30409.52013	SCREW HEX HD SS304 3/8 X 0-1/2 INCH	2
14	S75-30409.52025	WASHER FLAT SS304 3/8 " X 1" LGE/OD	2
15	P02-NYL025.0010.517	BUSH NYLON HR1200C COUGAR FOOT	4
16	P11-HAN304EXHR1200C	HANDLE EXTENSION 304 HR1200C COUGAR	1
17	S33-30404.76013	SCREW CSK SL MT 304 0-3/16 X 0-1/2 INCH	6
18	R41-ORG04203503.5	'O' RING SEAL 42X35X3.5 (BS220)	2
19	S33-30406.35025	SCREW CSK SL MT 304 0-1/4 X 1 INCH	4
20	S75-30409.52019	WASHER FLAT SS304 3/8 INCH X 0-3/4 INCH	4
21	P04-CAPBRZ01200C	CAPSTAN BRONZE HR1200C COUGAR	1
22	P02-GSH035.0025.039	SPACER G'SHAFT HR1200C CAPSTAN TG/SC OUT	1
23	P02-GSH035.0025.017	SPACER G'SHAFT HR1200C CAPSTAN TG/SC IN	1
24	P13-BRZLEVHR1200CL	PAWL LEVER HANDLE HR1200C COUGAR LH	1
25	P02-GSH035.0025.052	SPACER GUARDSHAFT HR1200C CAPSTAN	1

A: GYPSY
 B: MOTOR / GEARBOX ASSEMBLY



TOLERANCES (mm)	
X.	±
X.X	±
X.XX	±
UNLESS OTHERWISE SPECIFIED	
MATERIAL	
FINISH	

TITLE HR2500 COMPACT / TWIN GYP / SINGLE CAP EXPLODED VIEW / CAPSTAN TO PORT			
PART No. K08-COMHR2500C (CHEETAH)			
DRN AC	DATE 14/08/03	DRG No. K08-COMHR2500C	
SCALE NTS	APP1	APP2	SIZE A4
© COPYRIGHT MUIR ENGINEERING PTY. LTD.			

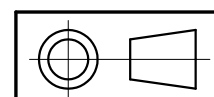

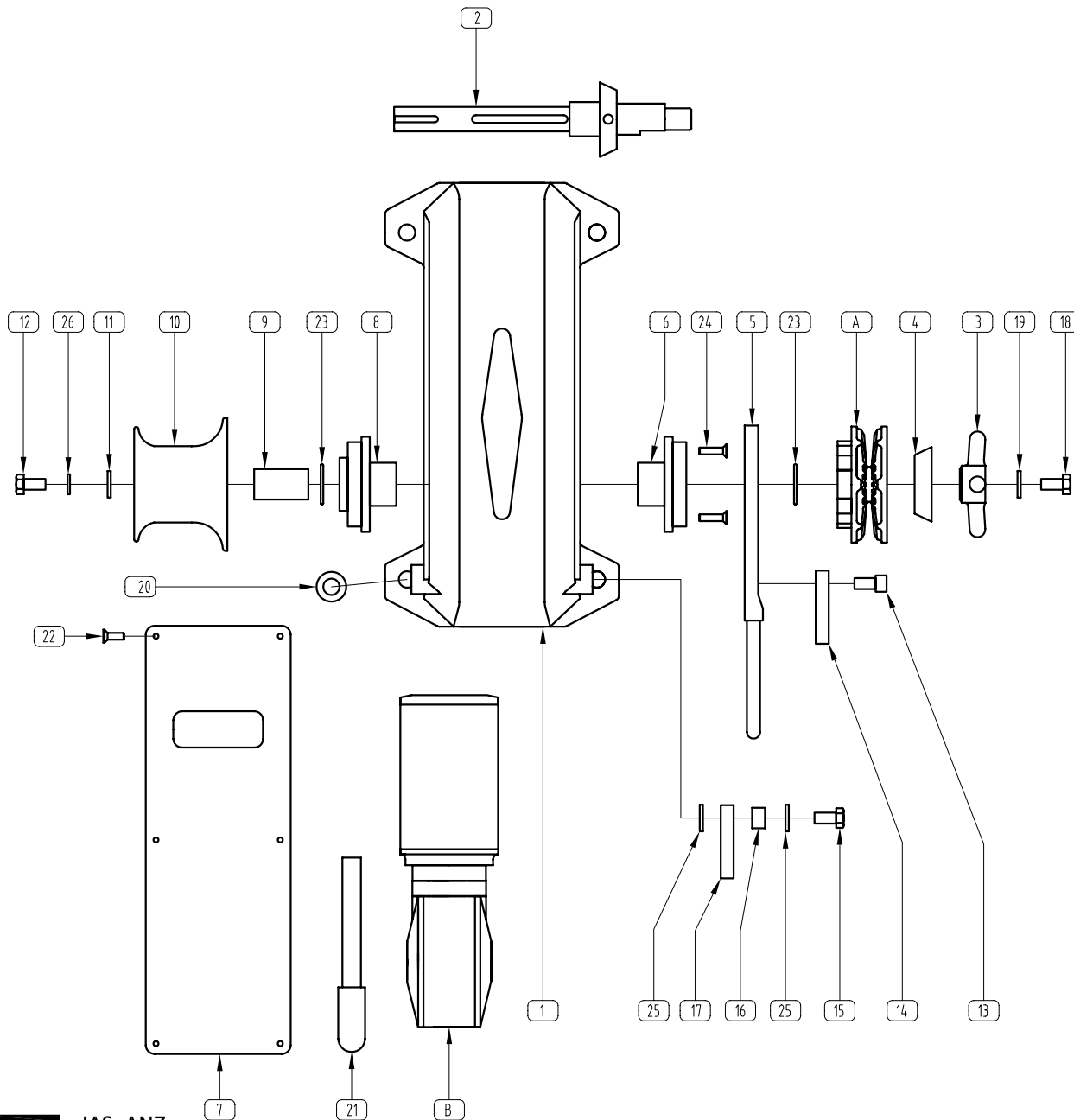

ITEM	PART NUMBER	DESCRIPTION	QTY
1	P22-HSGHR2500ATG	HOUSING ALLOY HR2500 CHEETAH TWIN GYPSY	1
2	K06-SFTHR2500A	SHAFT ASSEMBLY HR2500 CHEETAH SG/SC	1
3	P07-CLNBRZHR01200C	CLUTCH NUT BRONZE HR1200 COUGAR 3 PRONG	1
4	P08-CNEBRZHR01200CD	'D' CONE BRONZE HR1200C COUGAR	1
5	P11-HANAB2LEV01200C	HANDLE LEVER AB2 HR1200C COUGAR	1
6	P02-NOVHR01200CLH	BEARING LEVER HANDLE NOV HR1200C COUGAR	1
7	P22-BPLALLHR02500	BASE PLATE ALLOY HR2500 CHEETAH	1
8	P02-NOVHR01200CCSL	BEARING CAPSTAN SIDE NOV HR1200C LH	1
9	P02-GSH035.0025.052	SPACER GUARDSHAFT HR1200C CAPSTAN	1
10	P04-CAPBRZ01200C	CAPSTAN BRONZE HR1200C COUGAR	1
11	P21-BRS031.8009.503	WASHER BRASS 1-1/4" X 3/8" X 3MM	1
12	S36-30409.52025	SCREW HEX HD SS304 3/8 INCH X 1 INCH	1
13	S45-30407.94013	SCREW SHCS SS304 5/16 X 0-1/2 INCH	1
14	P13-BRZLEVHR1200CL	PAWL LEVER HANDLE HR1200C COUGAR LH	1
15	S13-30409.52038	BOLT HEX HD SS304 0-3/8 X 1-1/2 INCH	1
16	P02-303013.5009.314	BUSH SS303 HR1200C COUNTERWEIGHT PAWL	1
17	P13-BRZCWGHR1200C	PAWL COUNTERWEIGHT HR1200C COUGAR	1
18	S36-30409.52013	SCREW HEX HD SS304 3/8 X 0-1/2 INCH	1
19	S75-30409.52025	WASHER FLAT SS304 3/8 INCH 1 LGE/OD	1
20	P02-NYL025.0010.517	BUSH NYLON HR1200C COUGAR FOOT	4
21	P11-HAN304EXHR1200C	HANDLE EXTENSION 304 HR1200C COUGAR	1
22	S33-30404.76013	SCREW CSK SL MT 304 0-3/16 X 0-1/2 INCH	6
23	R41-ORG04203503.5	'O' RING SEAL 42X35X3.5 (BS220)	2
24	S33-30406.35025	SCREW CSK SL MT 304 0-1/4 X 1 INCH	2
25	S75-30409.52019	WASHER FLAT SS304 3/8 INCH X 0-3/4 INCH	2
26	S76-30409.52	WASHER SPRING SS304 3/8 INCH	1

A: GYPSY
B: MOTOR / GEARBOX ASSEMBLY



TOLERANCES (mm)		TITLE	
X.	±	HR2500 COMPACT / SINGLE GYPSY/CAPSTAN	
X.X	±	EXPLODED VIEW / CAPSTAN TO STARBOARD	
X.XX	±	PART No. K08-COMHR2500L (CHEETAH)	
UNLESS OTHERWISE SPECIFIED		DRN	DATE
MATERIAL		AC	02/08/02
FINISH		DRG No.	K08-COMHR2500L
		SCALE	SIZE
		NTS	A4
© COPYRIGHT MUIR ENGINEERING PTY. LTD.			

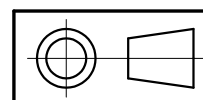



Head Office:

100 Browns Road,
Kingston Tasmania,
Australia 7050

Tel Int: +61 (0) 3 6211 8811

Fax Int: +61 (0) 3 6229 7030

Email: info@muir.com.au

www.muir.com.au

WINDLASS
SERIAL NUMBER

© 2005 Muir Engineering Pty. Ltd. Muir reserves the right to alter specifications without notice. All rights reserved.

While all due care and attention has been taken in the preparation of this manual no responsibility shall be taken for errors or omissions.

346

ALIGN SHEETS HERE

CUT OUT SECTION FOR HYDRAULIC LINES

CUT OUT SECTION FOR WIRING

4 HOLES $\phi 10.5$

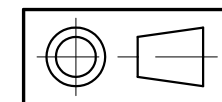
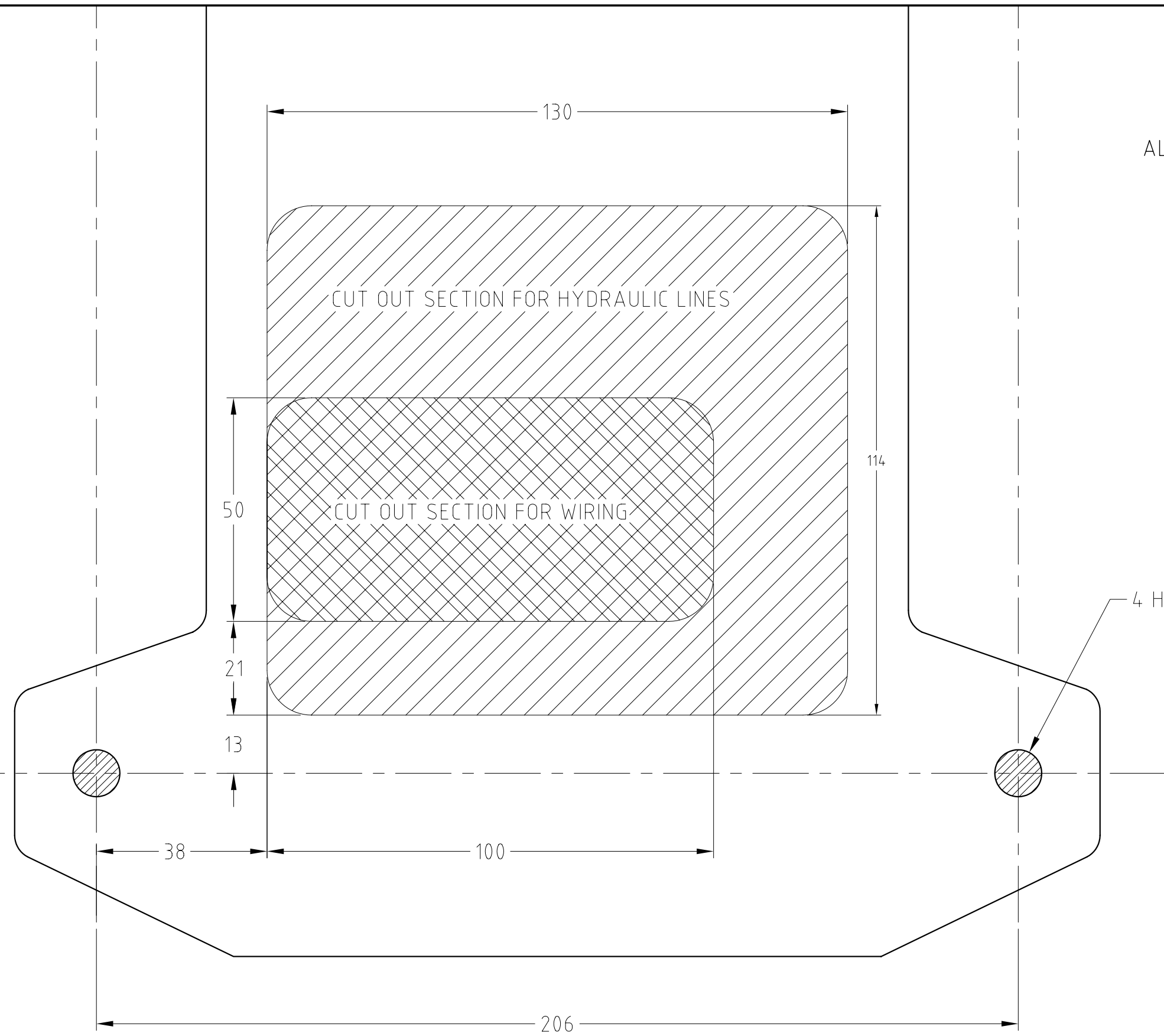

TOLERANCES (mm)	
X.	±
X.X	±
X.XX	±
UNLESS OTHERWISE SPECIFIED	
MATERIAL	
FINISH	

MUIR WINDLASSES AUSTRALIA			
TITLE HR 2500 CHEETAH DECK TEMPLATE DECK TEMPLATE			
PART No.			
DRN WQ	DATE 07/07/05	DRG No. CHEETAH DT	
SCALE 1:1	APP1	APP2	SIZE A3
© COPYRIGHT MUIR ENGINEERING PTY. LTD.			

