



A N C H O R I N G S Y S T E M S



imtra[®]
MARINE PRODUCTS



Photo: MJM Yachts



Photo: Sabre Yachts



Photo: Carver Yachts

TABLE OF CONTENTS

| | | |
|---|---|----|
| | INTRODUCTION | 3 |
| ■ | THE BASICS OF ANCHORING | 4 |
| | What you need to know about installing an anchoring system | |
| ■ | HOW TO SELECT A WINDLASS | 6 |
| | A guide to choosing the windlass that's best for your needs | |
| ■ | LOFRANS WINDLASSES | 8 |
| | Vertical Electric Windlasses | 10 |
| | Horizontal Electric Windlasses | 14 |
| | Manual Windlass | 20 |
| | Vertical Capstans | 21 |
| ■ | MUIR WINDLASSES | 22 |
| | Vertical Electric Windlasses | 24 |
| | Horizontal Electric Windlasses | 32 |
| ■ | SWITCHGEAR | 36 |
| | Footswitches | 36 |
| | Control Boxes & Breakers | 37 |
| | Control Panels | 38 |
| | Handheld Remote Controls | 39 |
| ■ | ANCHOR CHAIN & RODES | 40 |
| ■ | ACCESSORIES | 42 |
| ■ | ANCHOR ROLLERS | 44 |
| ■ | REFERENCE GUIDE | 46 |





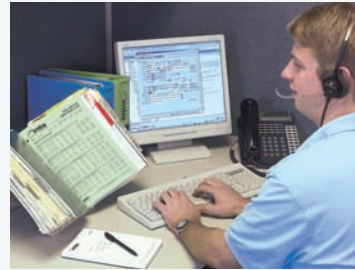
Your source for complete anchoring systems.

When you choose Imtra for your anchoring solutions, you can relax and enjoy impeccable performance, superior reliability and total peace of mind. At each step, Imtra provides you with the product selection, expertise and customer support that make all the difference.

We start by searching the world for the very best products, including windlasses from Lofrans and Muir, two brands recognized by boatbuilders for their quality and innovative engineering. In addition to windlasses, we offer a full range of switchgear and accessories to complete your system.



For more than 50 years, Imtra has built a solid reputation as a company that understands the marine industry. Our deep knowledge of marine systems allows us to provide customized solutions that go beyond standard installations to give you the best performance for your specific boating needs. We back up all of our products with expert technical support, prompt delivery and a focus on individual customer service that's unmatched in the industry. To get started, please contact Imtra at 508-995-7000 or visit our website at www.imtra.com.




www.imtra.com

Imtra Corporation, 30 Samuel Barnet Boulevard, New Bedford, MA 02745 Ph: 508.995.7000 Email: info@imtra.com

THE BASICS OF ANCHORING

What you need to know about installing an anchoring system.

With so much investment literally riding on your boat's anchoring system, it's essential to understand the basics of anchoring and the components you will need to complete a fully-integrated, high performance system. A well thought-out anchoring system will help make boating easier, safer, and more enjoyable for years to come.

Which system is best for you? Your choice depends on the size and type of your boat, as well as the anchoring conditions you typically encounter. Imtra has the extensive product selection you need for a customized solution. Individually, these are the top brands sought by boatbuilders and yachtsmen around the world. Together, these products function seamlessly as a comprehensive anchoring system:

Windlasses

A windlass is the backbone of any anchoring system. Imtra offers the complete range of windlasses from Lofrans [p.8](#) and Muir [p.22](#), the world's leaders in anchor windlasses. Choose from horizontal, vertical, electric (DC or AC), hydraulic or manual – every variation to meet your specific needs.

Footswitches

[p.36](#)

Most windlasses are operated by these simple **deck-mounted switches**. High-amperage models can operate a windlass without a control box. Low-amperage models make a good choice for customers using a control box who want a small deck cutout or multiple control stations.

Control Boxes

[p.37](#)

These watertight **control boxes** contain solenoids that interpret signals from the windlass operator (via footswitches, toggles, remote panels or handhelds). Pre-wired and fully sealed, they feature easy-access terminals for DC electric and control cables.

Circuit Breakers

[p.37](#)

Circuit breakers monitor the load on the windlasses' electrical system, protecting your boat and equipment against electrical overloads. They also act as a safety shut-off for the system. We offer different sizes to match the motor wattage of the windlass. Typically, the breaker's amperage rating should equal 10% of the motor wattage for 12VDC systems (5% for 24VDC).

SYSTEM OVERVIEW

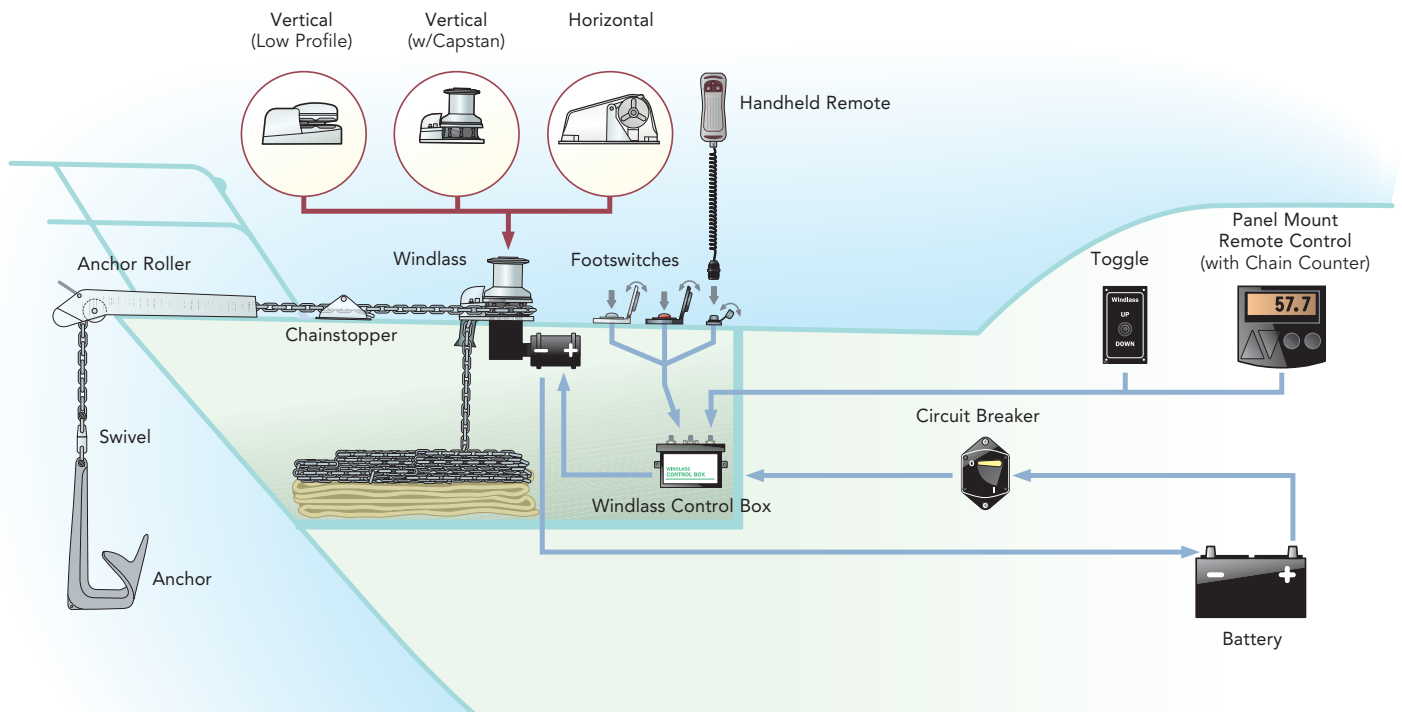




Photo: Cabo Yachts

Toggles and Panel Controls

p.38

Many boats offer **control panels** to operate a windlass from the helm station. Whether you choose a simple up/down toggle or a full-function, chain-counting panel-mount control system, Imtra has a control for you.

Handheld Remotes

p.39

Add-ons like **handheld remotes** can make operating your windlass so much easier. Fully watertight, these convenient controls allow you to move about the boat while controlling the windlass. They are even available with built-in chain counters and LED flashlights!

Anchor Rodes

p.40

Often overlooked in the design of anchoring systems, the **anchor rode** plays a more critical role than some may realize. Selecting the proper fit, material and length/size combination will ensure your windlass will payout and retrieve your anchor quickly, reliably and safely. Created to fit your own specifications, the options are endless. Available in stainless steel, HT, or BBB chain spliced expertly to high quality anchor line.

Chainstoppers

p.42

A must-have for boaters running all chain rodes, a **chainstopper** takes the load off the windlass and puts it safely on the boat when anchored. Our basic stainless steel versions suit most applications, though more elegant chrome-bronzed models are available for those desiring a more finished appearance. Larger yachts can even consider models with devil's claws to lock the anchor into its roller while underway.

Anchor Rollers

p.44

Our wide range of **anchor rollers** will protect your yacht and stow your anchor securely. All Imtra rollers offer Delrin® wheels for added durability.



Photo: Shutterstock

HOW TO SELECT A WINDLASS

The right anchor windlass makes all the difference.

The anchor windlass on your boat allows you to handle even the most difficult anchoring situations safely and with complete peace of mind. Choosing the right size and type



Photo: Pearson Yachts

of windlass for your vessel is the key to trouble-free boating.

Several factors play an important role when selecting a windlass: vessel type and size, displacement, anchor and chain size, and the anchoring environment.

The range of available models includes horizontal and vertical, manual and electric, and chain or combination rope/chain management.

Imtra has the technical expertise and extensive product selection to make your decision process easier. To help you get started, we offer the following handy guide.

Which windlass is the best for



Manual, Electric or Hydraulic

With a **Manual** windlass, you provide the energy. Manuals are less expensive, easier to install and require neither the wiring nor the plumbing of electric and hydraulic windlasses.

Electric windlasses are by far the most popular. They supply generous lifting power to make the retrieval of your anchor and rode a simple task of pressing a footswitch or pushing a button. They are compact in size and usually can be operated off the boat's existing electrical system.

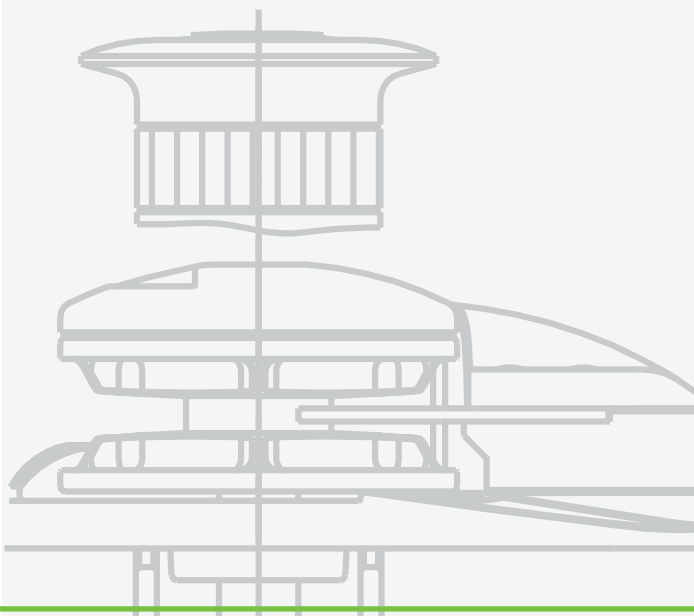
Hydraulic windlasses are extremely strong and efficient. They require a central hydraulic system within the yacht to power them. For this reason, they are usually fitted only on larger yachts with an existing hydraulic system that would control many systems on the boat.

Rope/Chain or All Chain

Today, most people fit combination rope/chain anchor rodes. These rodes combine a mid-length piece of chain (10-50') spliced to a high-quality 3-strand anchor line of a length selected by the owner. Most vertical windlasses are now designed to retrieve these combination rodes around a single gypsy or chainwheel. Some horizontals, typically for smaller boats, can also accept combination rope/chain rodes.

The primary advantage of **rope/chain** rodes is a savings in weight in the bow of the boat. The nylon anchor line also gives an element of elasticity to the rode that can be more comfortable at anchor in heavy weather.

Chain only rodes are much easier to retrieve reliably for all windlasses. Chain does not kink as anchor line can, therefore you avoid "hockles" that can sometimes slow the retrieval process. Chain is also stronger and usually allows the anchor rode to be set with less "scope" than a rope/chain rode.



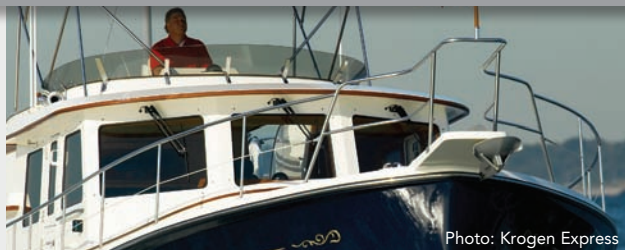
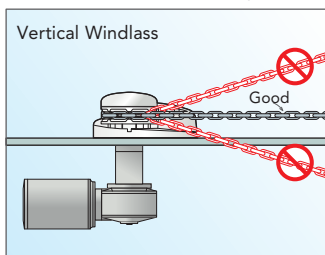


Photo: Krogen Express

my boat? Here are the most important things to consider before you buy.

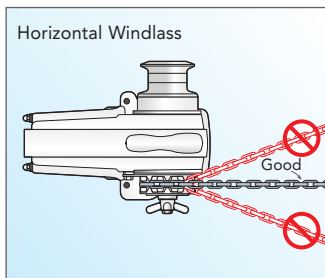
Vertical or Horizontal

Vertical windlasses place the chainwheel on a vertical drive shaft above the gearbox and motor, which are mounted below deck. The “topworks” can thus be lower in profile. Vertical windlasses often retrieve combination rope/chain rodes. The anchor rode should lead to the windlass parallel with the plane of the chainwheel for best results. The lead should be within 5 degrees of level to the chainwheel for the best results.



The anchor chain should have a straight entry to the winch, not entering from a vertical angle.

Horizontal models mount the chainwheel and capstan on either side of the on-deck housing which usually contains both the motor and gearbox. Horizontals make very good choices for boats with little space below deck to mount the motor and gearbox. Most horizontals retrieve rope and chain separately. For this reason, most owners of horizontals choose all chain rodes. The lead of the anchor rode on the horizontal should also be in line with the plane of the chainwheel.



The anchor chain should have a straight entry to the winch, not entering from Port or Starboard.

Sizing Considerations

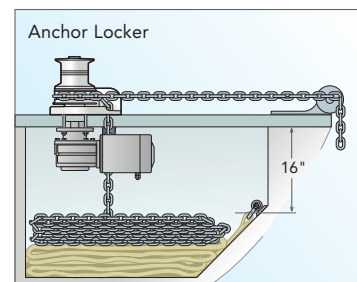
The windlass is intended to lift the anchor and ground tackle, not to pull or drag the boat. A typical rule of thumb is to take the total weight of your anchor and complete anchor rode and multiply that by a factor of three. This number should be less than the power rating of the windlass. On the introductory pages for each windlass brand, we include charts of the typical boat sizes for each model.

Use these charts to get an idea of what size is right for you. We also strongly recommend that you consult marine professionals to determine what size windlass is right for your boat. You can also contact Imtra at 508-995-7000 to discuss your individual requirements.

Mounting Locations

With both horizontal and vertical models, a windlass should normally be mounted on the yacht’s centerline with the chain in close alignment to a line drawn from the chainwheel through the bow roller (or chock) to straight ahead in the water. It is important, especially for combination rodes, to locate your windlass so that, as rope is stripped from chain-wheel or drum, it can “fall” directly into the rope locker.

The location and depth of an anchor locker are important elements in a windlass installation. When the rode is in the anchor locker, the top of the anchor rode should be a minimum of 16" below the underside of the deck. The anchor locker should also be positioned so the chain and rope feed through the windlass deck plate or hawsepipe directly into the deepest section of the anchor locker.



Installation

For your convenience, Imtra provides easy access to technical information on windlass installation at our website. Go to www.imtra.com and simply download the files you need, including owners manuals, parts diagrams, dimensional drawings and more. If you need technical advice or other information, our knowledgeable staff is ready to help at 508-995-7000.



Photo: Hunter Yachts

LOFRANS WINDLASSES



Lofrans – for three generations a worldwide reputation for engineering excellence.

Lofrans was founded in 1966 in Monza, Italy, with a determined focus: to design and manufacture the highest quality anchor windlasses at competitive pricing.



Over the years, this commitment, along with technical expertise and innovation, has led to impressive results.

Today, Lofrans is a world leader in the manufacture of anchor windlasses.

A large base of customers – from yachtsmen to prominent boat builders – have made Lofrans their windlass of choice.

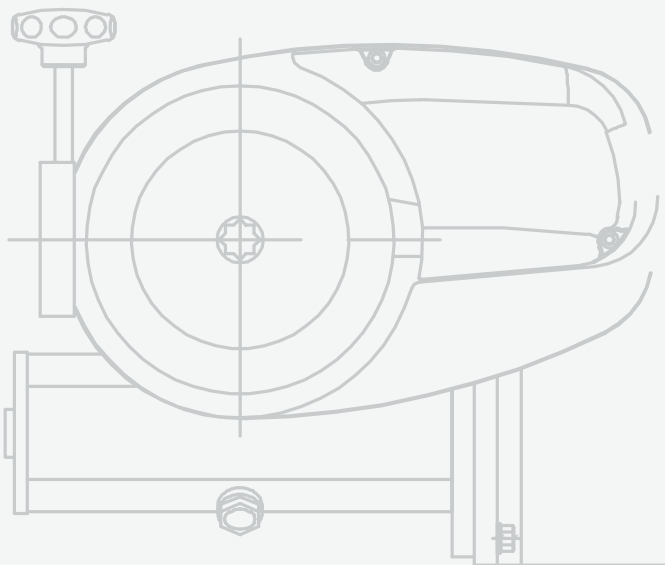


Photo: Intrepid Yachts

What sets Lofrans apart.

Lofrans is recognized throughout the boating industry for quality engineering and rugged durability. Lofrans windlasses stand the test of time, providing years of exceptional performance for owners of boats from 20' to 80' and more.

Purpose-built for marine use.

All the components of a Lofrans windlass are designed and manufactured specifically for the harsh marine environment. The mainshafts are made of AISI 431 stainless steel for durability.

Vertical topworks are cast of marine-grade bronze and chrome-plated to a mirror finish. Horizontal housings are made of a special aluminum alloy, polished and then anodized. Wormwheels are alloy bronze and wormscrews are 38NCD4 stainless steel.



Hot-forged components are supplied with most models. Hot-forging provides high mechanical strength, better surface conditions, and a more compact molecular structure than traditional cast parts.

Gearboxes are corrosion-resistant anodized aluminum and have ratios between 1:50 and 1:75 for the ideal balance of performance and speed. Lofrans electric motors are IP56 for marine use. Most are series-wound, which produces an initial starting torque that provides a critical advantage over permanent magnet motors.

The latest in engineering and design.

Through innovative engineering and advanced design, Lofrans maintains its leadership position in the market. Robust construction has made our solid horizontal models popular for



Photo: Caliber Yachts

heavy-use vessels such as charter boats, world cruisers and live-aboards.

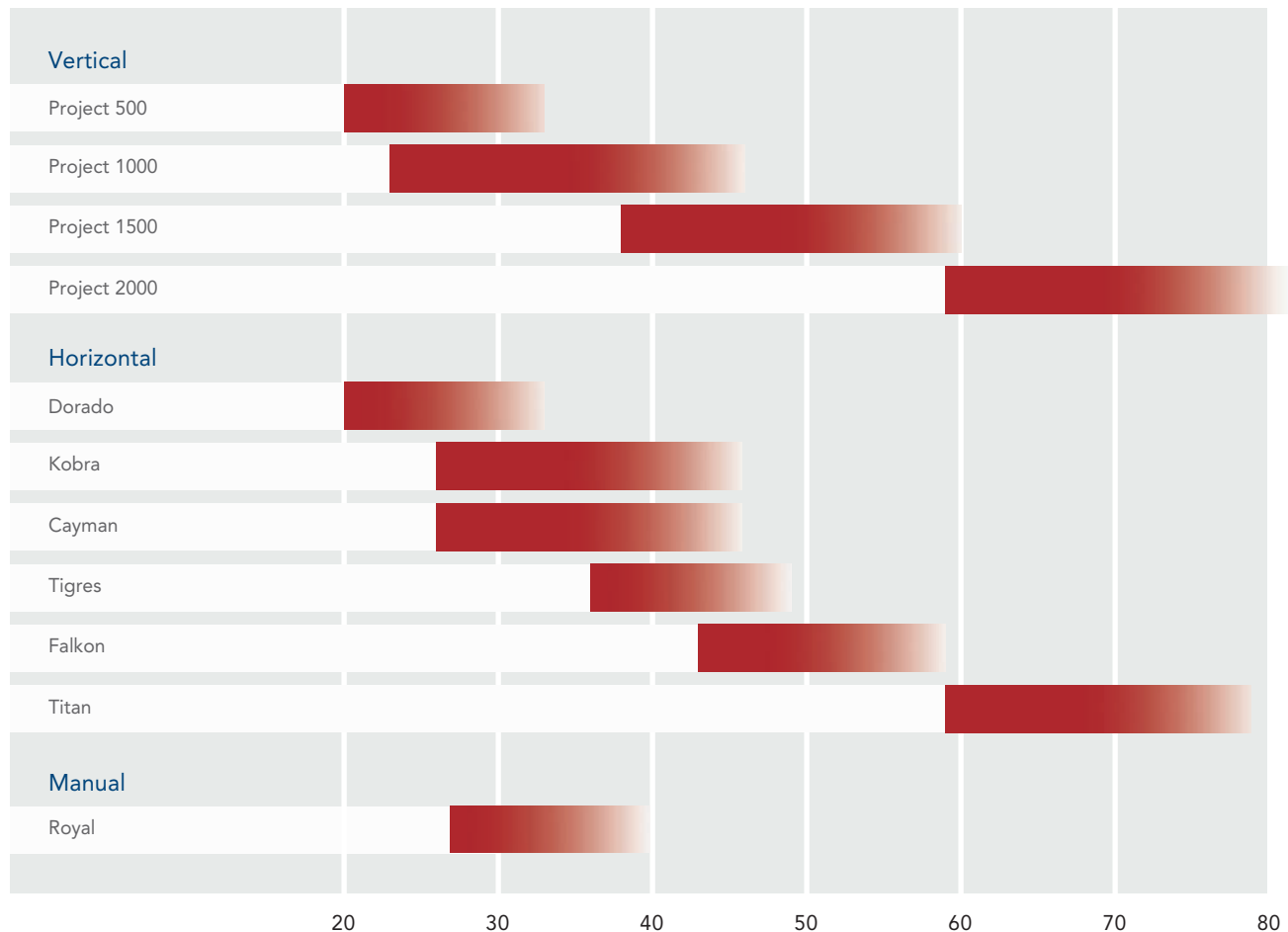
Lofrans vertical models offer contemporary styling and the latest features. Keyless

mainshafts handle any unforeseen shockloads, unlike traditional keyway design.

Vertical or horizontal, electric or manual – Lofrans has it!

LOFRANS WINDLASS SELECTION GUIDE

Lofrans manufactures recreational windlasses to fit vessels from 20'-82' in length. Use this chart as a basic guide to help determine which type and model is best for you.



PLEASE NOTE: Recommendations for model selection by yacht length are intended for guidance purposes only; actual selection should be made after consulting with competent engineers.

A network of support.

Imtra’s highly-trained regional representatives allow us to maintain close contact with individuals and marine tradespeople, and our knowledgeable in-house service department provides timely repairs and specialized windlass services to our customers (call for details). We are proud to back up our Lofrans product selection with technical expertise, online services, extensive product and parts availability as well as full warranty service throughout North America.



LOFRANS WINDLASSES

VERTICAL

Project 500

Vertical rope/chain windlass for boats under 33'.

The Project 500 can handle setting a lunch hook or an all chain rode in a heavy squall with power to spare. Two motors available (500W and 700W).

Standard Equipment

- Two footswitches
- Watertight control box
- Clutch release handle
- Neoprene mounting gasket

Features

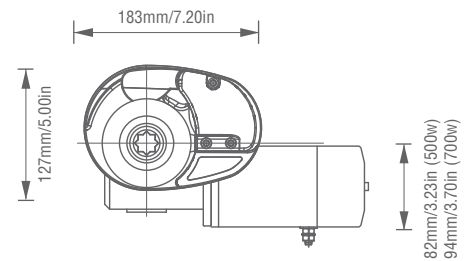
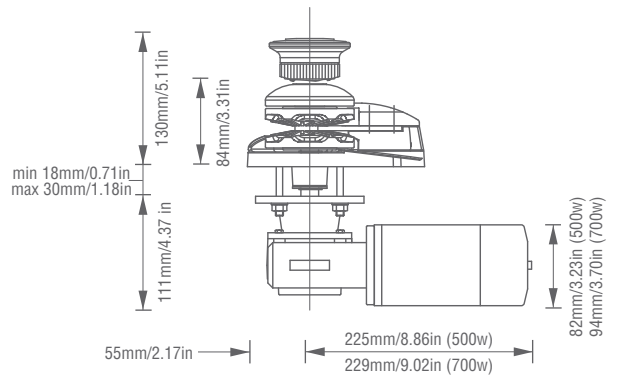
| | |
|----------------------|--|
| Finish | Chrome |
| Motor | (500W): Dual Direction, Permanent Magnet (700W): Dual Direction, Permanent Magnet |
| Gearbox | Stainless Worm Drive Radially Adjustable |
| Gears | Bronze |
| Mainshaft | Stainless |
| Chainpipe | Fixed |
| Chain Stripper | Stainless |
| Mounting Hardware | SS Studs, Washers and Nuts |
| Manual Override | N/A |
| Rope Capstan | Optional |
| Extra Deck Clearance | Optional (to 4 ³ / ₄ ") |

Specifications

| | | |
|--------------------------------|-------|-------|
| Power Supply | 12V | 12V |
| Motor Wattage | 500W | 700W |
| Power Rating (lbs.) | 850 | 950 |
| Approx. Amp Draw | 30-60 | 35-70 |
| Max Retrieval Speed (ft./min.) | 65 | 65 |
| Chain Size | 1/4" | |
| Rope Size | 1/2" | |
| Net Weight (lbs.) | 22 | 25 |

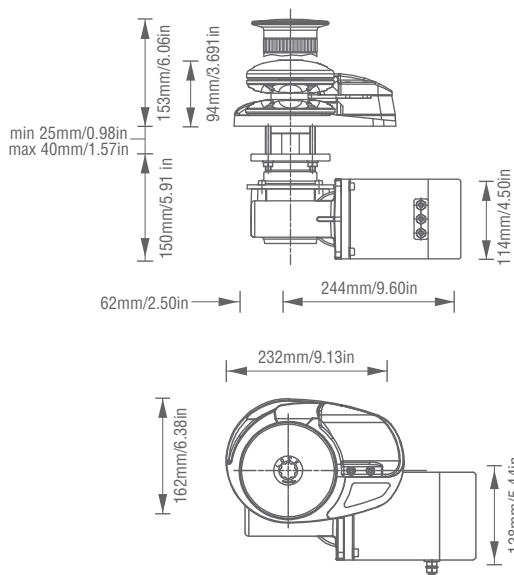


Photo: Sea Ray, Inc.



Vertical electric windlasses in low profile or capstan versions.

VERTICAL



Project 1000

Vertical rope/chain windlass for boats from 23'-46'.

The Project 1000 is a robust, powerful rope/chain windlass capable of managing all chain rodes for bluewater cruisers and coastal cruisers alike.

Standard Equipment

- Two footswitches
- Watertight control box
- Clutch/manual operation handle
- Neoprene mounting gasket

Features

| | |
|----------------------|---|
| Finish | Chrome |
| Motor | Dual Direction, Series Wound |
| Gearbox | Stainless Worm Drive Radially Adjustable |
| Gears | Bronze |
| Mainshaft | Stainless |
| Chainpipe | Fixed |
| Chain Stripper | Stainless |
| Mounting Hardware | SS Studs, Washers and Nuts |
| Manual Override | Standard |
| Rope Capstan | Optional |
| Extra Deck Clearance | Optional (to 5") |

Specifications

| | | |
|--------------------------------|-------------|-------|
| Power Supply | 12V | 24V |
| Motor Wattage | 1000W | 1000W |
| Power Rating (lbs.) | 1450 | 1450 |
| Approx. Amp Draw | 70-120 | 40-60 |
| Max Retrieval Speed (ft./min.) | 75 | 75 |
| Chain Size | 5/16" | |
| Rope Size | 9/16", 5/8" | |
| Net Weight (lbs.) | 45 | 45 |

LOFRANS WINDLASSES

factoid Low Profile or Capstan?

All Lofrans vertical windlasses are offered with and without a rope capstan. Low profile versions keep the foredeck uncluttered and visually pleasing. Capstan versions have a rope drum that operates independently of the rope/chain gypsy, an advantage when using two anchors or as a snubbing winch in docking maneuvers.

LOFRANS WINDLASSES

VERTICAL

Project 1500

Vertical rope/chain windlass for boats from 39'-59'.

The Project 1500 is available with a variety of motor and gypsy combinations and low profile models feature Lofrans' lockable clutch system.

Standard Equipment

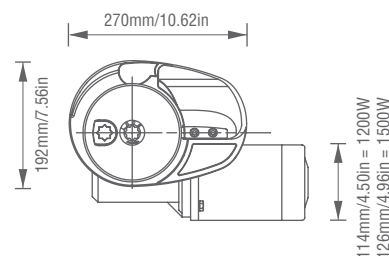
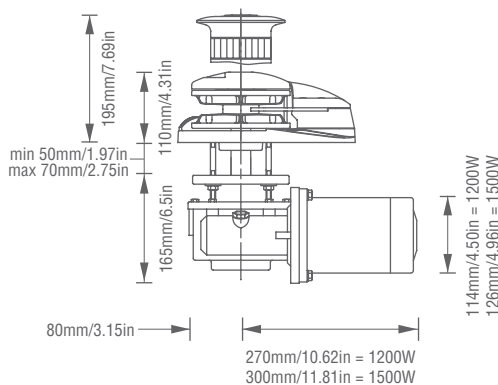
- Two footswitches
- Watertight control box
- Clutch/manual operation handle
- Neoprene mounting gasket

Features

| | |
|----------------------|---|
| Finish | Chrome |
| Motor | Dual Direction, Series Wound |
| Gearbox | Stainless Worm Drive Radially Adjustable |
| Gears | Bronze |
| Mainshaft | Stainless |
| Chainpipe | Fixed |
| Chain Stripper | Stainless |
| Mounting Hardware | SS Studs, Washers and Nuts |
| Manual Override | Standard |
| Rope Capstan | Optional |
| Extra Deck Clearance | Optional (to 5") |

Specifications

| | | |
|--------------------------------|-----------------------------|-----------------------------|
| Power Supply | 12V or 24V | 12V or 24V |
| Motor Wattage | 1200W | 1500W |
| Power Rating (lbs.) | 1700 | 2300 |
| Approx. Amp Draw | 80-135 (12V) 50-70 (24V) | 90-135 (12V) 50-70 (24V) |
| Max Retrieval Speed (ft./min.) | 60 | 60 |
| Chain Size | 5/16", 3/8" | |
| Rope Size | 5/8", 3/4" | |
| Net Weight (lbs.) | 62 | 69 |



Vertical electric windlasses in low profile or capstan versions.

VERTICAL

Project 2000

Vertical all chain windlass for boats from 59'-82'.

The Project 2000 is ideal for larger, bluewater yachts both new and classic. The gypsy manages all chain rodes. Capstan version handles 9/16" - 3/4" rope.

Standard Equipment

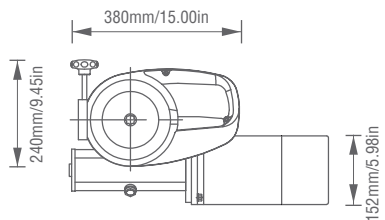
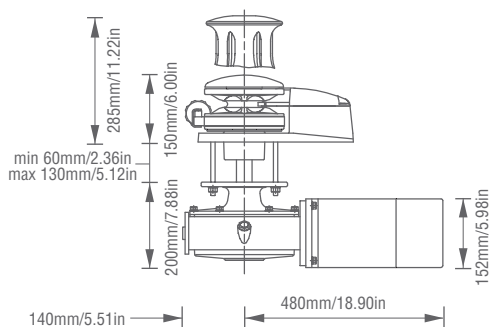
- Two footswitches
- Watertight control box
- Clutch/manual operation handle
- Brake band

Features

| | |
|----------------------|---|
| Finish | Chrome |
| Motor | Dual Direction, Series Wound |
| Gearbox | Stainless Worm Drive Radially Adjustable |
| Gears | Bronze |
| Mainshaft | Stainless |
| Chainpipe | Fixed |
| Chain Stripper | Stainless |
| Mounting Hardware | SS Studs, Washers and Nuts |
| Manual Override | Standard |
| Rope Capstan | Optional |
| Extra Deck Clearance | Optional (to 6") |

Specifications

| | | |
|--------------------------------|-----------------------------|---------|
| Power Supply | 24V | 24V |
| Motor Wattage | 2000W | 2500W |
| Power Rating (lbs.) | 2800 | 3100 |
| Approx. Amp Draw | 90-110 | 100-120 |
| Max Retrieval Speed (ft./min.) | 78 | 78 |
| Chain Size | 5/16", 3/8", 7/16", 1/2" | |
| Rope Size | 9/16" - 3/4" (Capstan only) | |
| Net Weight (lbs.) | 159 | 159 |



LOFRANS WINDLASSES

HORIZONTAL

Dorado

Horizontal rope/chain windlass for boats up to 32'.

Dorado's vertically-mounted motor and small profile are ideal for boats with restricted anchor lockers. Offered with 500W or 700W motor.

Standard Equipment

Watertight control box
Clutch release handle
Neoprene mounting gasket

Features

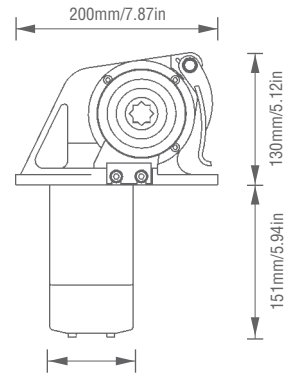
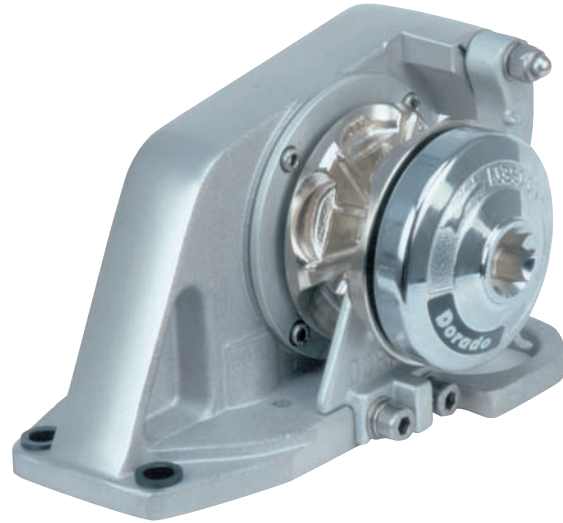
| | |
|----------------------|--|
| Finish | Anodized |
| Motor | (500W): Dual Direction, Permanent Magnet (700W): Dual Direction, Permanent Magnet |
| Gearbox | Stainless Worm Drive |
| Gears | Bronze |
| Mainshaft | Stainless |
| Chainpipe | Deck Ring |
| Chain Stripper | Aluminum |
| Mounting Hardware | Insulated Bushings Only |
| Manual Override | N/A |
| Rope Capstan | N/A |
| Extra Deck Clearance | N/A |

Specifications

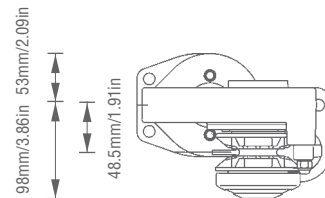
| | | |
|--------------------------------|-------|-------|
| Power Supply | 12V | 12V |
| Motor Wattage | 500W | 700W |
| Power Rating (lbs.) | 850 | 1000 |
| Approx. Amp Draw | 30-50 | 60-80 |
| Max Retrieval Speed (ft./min.) | 49 | 59 |
| Chain Size | 1/4" | |
| Rope Size | 1/2" | |
| Net Weight (lbs.) | 15 | 20 |



Photo: Striper Boats



500W:82mm/3.23in; 700W:94mm/3.70in



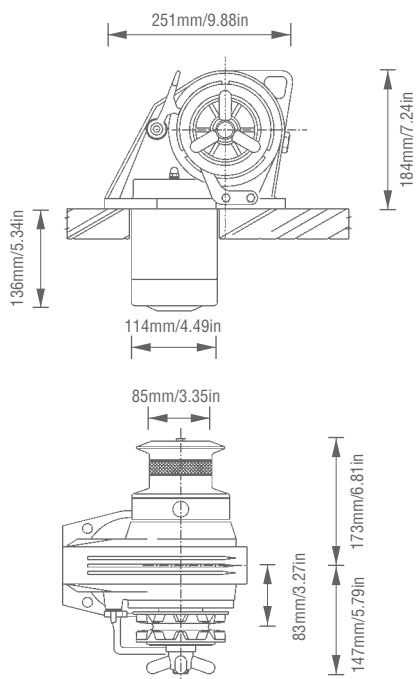
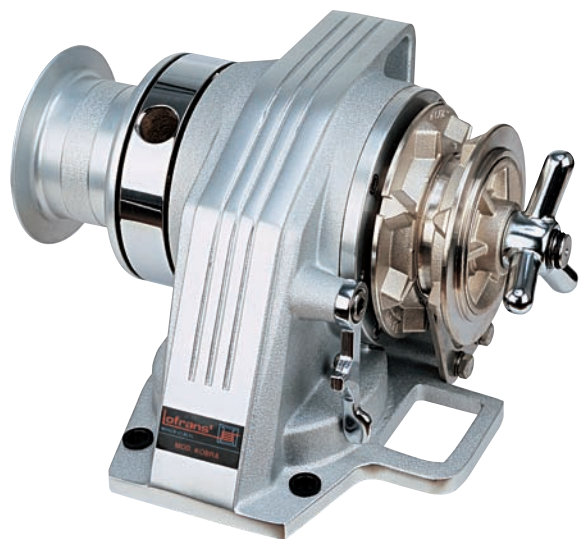
Drop-In Installation

factoid

Drop-in installations are quick, simple, and ideal for small or restricted anchor lockers. The motor installs vertically directly under the windlass housing to save space. The assembled windlass is mounted by passing the motor through the deck hole. Only stud tightening and wire connections are done from under the deck.

Horizontal electric winches (with drop-in motor) for boats from 20' to 46'.

HORIZONTAL



Kobra

Horizontal windlass for boats from 26'-46'.

Kobra's vertically-aligned motor and compact above-deck profile make it ideal for crowded foredecks and installations where space is limited.

Standard Equipment

- Two footswitches
- Watertight control box
- Clutch/manual operation handle

Features

| | |
|----------------------|----------------------------------|
| Finish | Anodized |
| Motor | Dual Direction, Permanent Magnet |
| Gearbox | Stainless Worm Drive |
| Gears | Bronze |
| Mainshaft | Stainless |
| Chainpipe | Deck Ring |
| Chain Stripper | Stainless |
| Mounting Hardware | Insulated Bushings Only |
| Manual Override | Standard |
| Rope Capstan | Standard |
| Extra Deck Clearance | N/A |

Specifications

| | | |
|--------------------------------|-------------------|-------|
| Power Supply | 12V | 24V |
| Motor Wattage | 1000W | 1000W |
| Power Rating (lbs.) | 1400 | 1400 |
| Approx. Amp Draw | 70-100 | 40-60 |
| Max Retrieval Speed (ft./min.) | 65 | 65 |
| Chain Size | 1/4", 5/16", 3/8" | |
| Rope Size | 1/2" - 3/4" | |
| Net Weight (lbs.) | 42 | 42 |

LOFRANS WINDLASSES

HORIZONTAL

Cayman

Horizontal windlass for boats from 26'-46'.

Sturdy, sleek and compact, Cayman features a 1000W motor, standard manual override, all chain retrieval and separate rope capstan. Mounting studs thread discreetly into the housing.

Standard Equipment

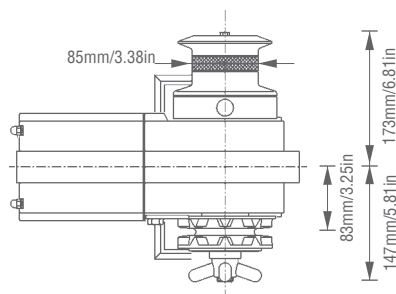
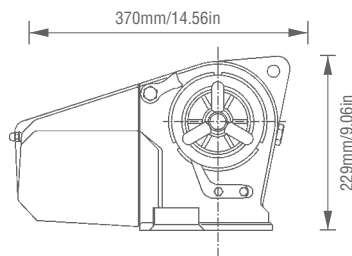
- Two footswitches
- Watertight control box
- Clutch/manual operation handle
- Rubber mounting gasket

Features

| | |
|----------------------|------------------------------|
| Finish | Anodized |
| Motor | Dual Direction, Series Wound |
| Gearbox | Stainless Worm Drive |
| Gears | Bronze |
| Mainshaft | Stainless |
| Chainpipe | Rubber Ring |
| Chain Stripper | Stainless |
| Mounting Hardware | SS Studs, Washers and Nuts |
| Manual Override | Standard |
| Rope Capstan | Standard |
| Extra Deck Clearance | N/A |

Specifications

| | | |
|--------------------------------|-------------------|-------|
| Power Supply | 12V | 24V |
| Motor Wattage | 1000W | 1000W |
| Power Rating (lbs.) | 1400 | 1400 |
| Approx. Amp Draw | 70-100 | 40-60 |
| Max Retrieval Speed (ft./min.) | 65 | 65 |
| Chain Size | 1/4", 5/16", 3/8" | |
| Rope Size | 1/2" - 3/4" | |
| Net Weight (lbs.) | 44 | 44 |



Horizontal chain or rope windlasses for boats from 26' to 49'.

HORIZONTAL

Tigres

Horizontal windlass for boats from 36'-49'.

One of the all-time most popular windlasses, Tigres' unique features include a handy top mounted snubbing cleat, standard manual overdrive, all chain retrieval, and oil-level window. Charter companies select Tigres for its durable, trouble-free design.

Standard Equipment

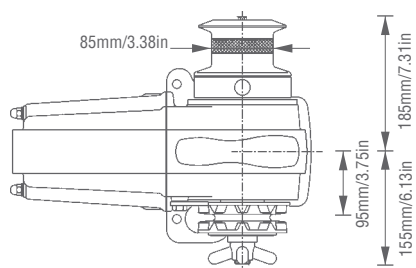
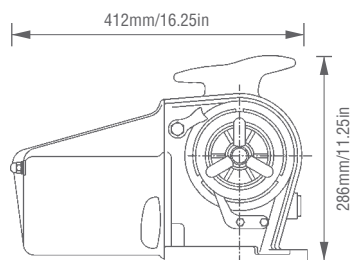
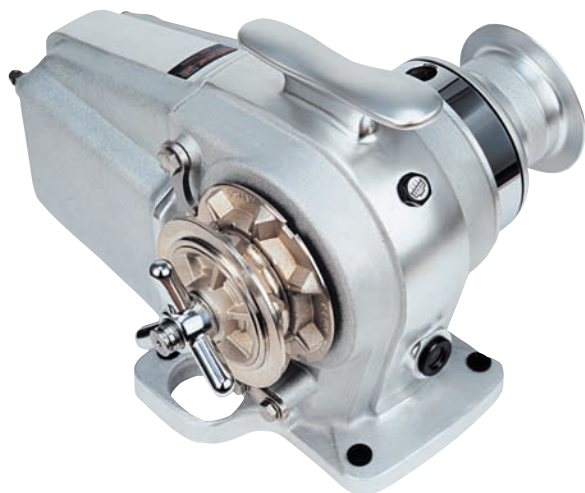
- Two footswitches
- Watertight control box
- Clutch/manual operation handle

Features

| | |
|----------------------|------------------------------|
| Finish | Anodized |
| Motor | Dual Direction, Series Wound |
| Gearbox | Stainless Worm Drive |
| Gears | Bronze |
| Mainshaft | Stainless |
| Chainpipe | Deck Ring |
| Chain Stripper | Stainless |
| Mounting Hardware | Insulated Bushings Only |
| Manual Override | Standard |
| Rope Capstan | Standard |
| Extra Deck Clearance | N/A |

Specifications

| | | |
|--------------------------------|-------------------|-------|
| Power Supply | 12V | 24V |
| Motor Wattage | 1200W | 1200W |
| Power Rating (lbs.) | 1700 | 1700 |
| Approx. Amp Draw | 80-110 | 50-60 |
| Max Retrieval Speed (ft./min.) | 72 | 72 |
| Chain Size | 1/4", 5/16", 3/8" | |
| Rope Size | 1/2" - 3/4" | |
| Net Weight (lbs.) | 53 | 53 |



LOFRANS WINDLASSES

HORIZONTAL

Falkon

Horizontal windlass for boats from 43'-59'.

Falkon is ideal for large cruising vessels that anchor frequently with heavy offshore, all chain ground tackle. Once the rode is in place, back up your chainstopper with the included brake band. Contact Imtra for details on special versions, including dual gypsies, or custom configurations.

Standard Equipment

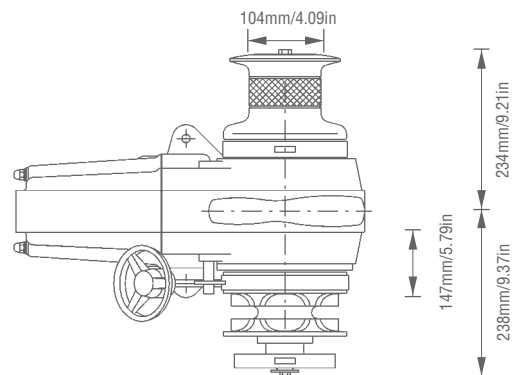
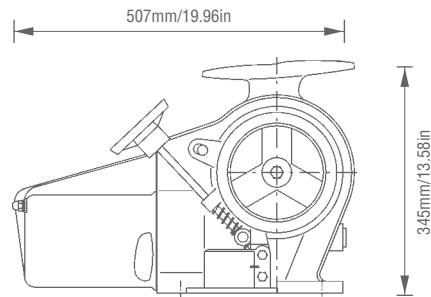
- Two footswitches
- Watertight control box
- Clutch/manual operation handle

Features

| | |
|----------------------|------------------------------|
| Finish | Anodized |
| Motor | Dual Direction, Series Wound |
| Gearbox | Stainless Worm Drive |
| Gears | Bronze |
| Mainshaft | Stainless |
| Chainpipe | Stand-Alone w/Adj. Stripper |
| Chain Stripper | Stainless |
| Mounting Hardware | Insulated Bushings Only |
| Manual Override | Standard |
| Rope Capstan | Standard |
| Extra Deck Clearance | N/A |

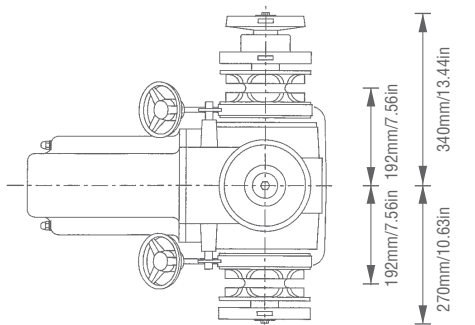
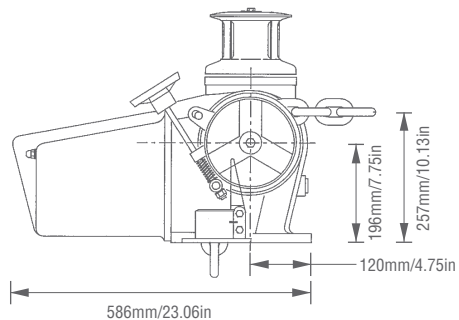
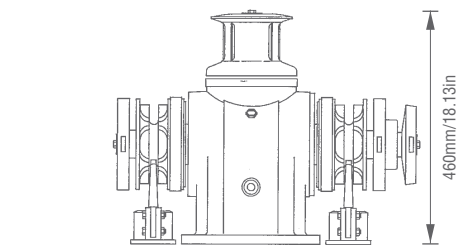
Specifications

| | | |
|--------------------------------|--------------------------|-------|
| Power Supply | 12V | 24V |
| Motor Wattage | 1500W | 1500W |
| Power Rating (lbs.) | 2500 | 2500 |
| Approx. Amp Draw | 90-120 | 50-70 |
| Max Retrieval Speed (ft./min.) | 56 | 56 |
| Chain Size | 5/16", 3/8", 7/16", 1/2" | |
| Rope Size | 1/2" - 3/4" | |
| Net Weight (lbs.) | 103 | 103 |



Horizontal electric windlasses for boats from 43' to 90'.

HORIZONTAL



Titan

Horizontal heavy-lift windlass for boats from 70'-90'.

Titan is designed for big boat tackle, and is available in a variety of configurations. The popular "B" model (shown) includes gypsies to starboard and port for ground tackle retrieval, and a convenient top-mounted rope drum. Contact Imtra for custom configurations.

Standard Equipment

- Two footswitches
- Watertight control box
- Clutch/manual operation handle

Features

| | |
|----------------------|---|
| Finish | Anodized |
| Motor | DC: Dual Direction, Series Wound AC: Various Motor Options Available |
| Gearbox | Stainless Worm Drive |
| Gears | Bronze |
| Mainshaft | Stainless |
| Chainpipe | Stand-Alone w/ Adj. Stripper |
| Chain Stripper | Stainless |
| Mounting Hardware | Insulated Bushings Only |
| Manual Override | Standard |
| Rope Capstan | Standard |
| Extra Deck Clearance | N/A |

Specifications

| | |
|--------------------------------|-------------------|
| Power Supply | 24V |
| Motor Wattage | 2000W |
| Power Rating (lbs.) | 3100 |
| Approx. Amp Draw | 80-110 |
| Max Retrieval Speed (ft./min.) | 46 |
| Chain Size | 3/8", 7/16", 1/2" |
| Rope Size | 1/2" - 3/4" |
| Net Weight (lbs.) | 165 - 211 |

For details on AC units, please contact Imtra at 508-995-7000.

LOFRANS WINDLASSES

MANUAL

Royal

Manual rope/chain windlass for boats from 26'-39'.

For some smaller vessels without sufficient electrical systems, a manual windlass makes sense. Royal is easy to install and features a smooth, double-action operation that makes anchoring a quick and simple task.

Standard Equipment

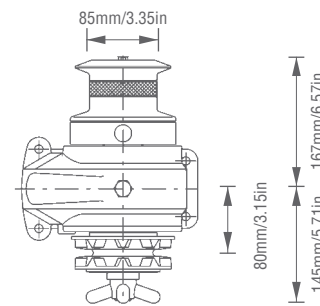
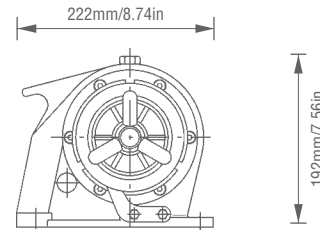
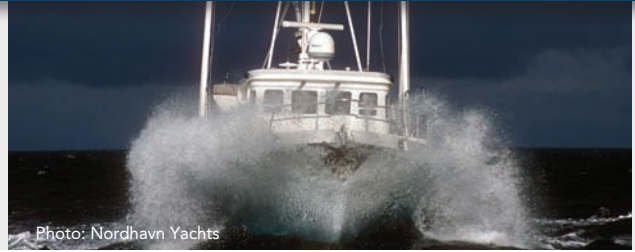
Manual operation handle

Features

| | |
|----------------------|-------------------------|
| Finish | Anodized |
| Motor | N/A |
| Gearbox | Bevel Gears |
| Gears | Aluminum |
| Gear Ratio | 1.2:1 |
| Mainshaft | Stainless |
| Chainpipe | Not Included |
| Chain Stripper | Stainless |
| Mounting Hardware | Insulated Bushings Only |
| Manual Override | Standard |
| Rope Capstan | Standard |
| Extra Deck Clearance | N/A |

Specifications

| | |
|---------------------|-------------------|
| Power Rating (lbs.) | 440 |
| Chain Size | 1/4", 5/16", 3/8" |
| Rope Size | 1/2" - 3/4" |
| Net Weight (lbs.) | 20 |



When a Manual is the Right Choice.

factoid

In many circumstances, a manual windlass makes the most sense. Electrical limitations, infrequent anchoring and often budget considerations, make this choice a significant upgrade from the back-breaking, hand-over-hand method of recovering ground tackle.

Manual rope/chain windlass and electric rope capstans in a variety of sizes.

CAPSTANS

Vertical Capstans

Typically installed on the stern to aid in docking and mooring situations. Lofrans vertical capstans feature the same high quality chrome warping drums and gearboxes as our windlasses.

Standard Equipment

- Footswitch
- Watertight control box



LOFRANS WINDLASSES

| Features | T1000 | T1200 | T1500 | T2000 |
|-----------------------|------------------------------|------------------------------|------------------------------|------------------------------|
| Finish | Chrome | Chrome | Chrome | Chrome |
| Motor | Dual Direction, Series Wound | Dual Direction, Series Wound | Dual Direction, Series Wound | Dual Direction, Series Wound |
| Gearbox | Stainless Worm Drive | Stainless Worm Drive | Stainless Worm Drive | Stainless Worm Drive |
| Mainshaft | Stainless | Stainless | Stainless | Stainless |
| Mounting Hardware | SS Studs, Washers, Nuts | SS Studs, Washers, Nuts | SS Studs, Washers, Nuts | SS Studs, Washers, Nuts |
| Extra Deck Clearance | Optional | Optional | Optional | Optional |
| Specifications | | | | |
| Power Supply | 12/24V | 12/24V | 12/24V | 24V |
| Motor Wattage | 1000W | 1200W | 1500W | 2000W |
| Power Rating | 1400 lbs. | 1700 lbs. | 2300 lbs. | 2800 lbs. |
| Retrieval Speed | 46-59'/min. | 49-59'/min. | 49-59'/min. | 52-62'/min. |
| Net Weight (lbs.) | 40 | 55 | 62 | 132 |

Dimensions: For diagrams showing dimensions for each vertical capstan, please visit www.imtra.com

MUIR WINDLASSES



Muir – a dominant force for innovative anchoring technology and dependability.

Since 1968, Muir has been recognized as an industry leader in anchoring systems worldwide. Muir windlasses and anchoring systems rest on the deck of many of the world’s largest and



most respected production-built vessels.

A Muir anchoring system is an investment in security and peace of mind. Utilizing the most advanced technologies, Muir technicians and engineers have developed systems to suit the luxury mega yacht, pleasure craft and commercial vessel market.

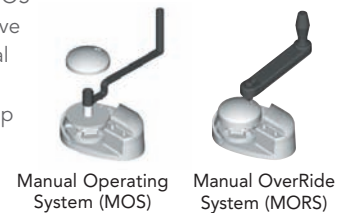
In recognition of this expertise, Muir has received numerous industry awards, including Tasmania’s Exporter of the Year.



Muir innovation and integrity.

Muir have not only perfected the rope/chain combination windlass but developed the Rope/Chain Management System for smooth rope/chain transition. They have advanced the windlass ratchet system for controlled manual override, and integrated complete units with swivel chain pipes onto a single base.

Muir Atlantic vertical windlasses are available with two different clutch systems. Models with MOS (Manual Operating System) have a fixed cone clutch. For manual anchor recovery, remove the capstan (on VRC models) or top cap (VR units) and insert a special handle (ordered separately) into the top of the gypsy.



Models with MORS (Manual Over Ride System) feature a ratchet pawl assembly within the cone clutch. These units can be configured in two ways: electric dual direction (for power up and down) or electric retrieval with manual override. When in the latter configuration, manual recovery of the anchor is accomplished by inserting a standard winch handle (one is included with each windlass) directly into the top of the capstan or clutch cap.

If the unit is configured for dual-direction electrical operation, manual retrieval is still possible after re-positioning the ratchet pawls, located underneath the cone clutch. Most users configure windlasses with MORS for dual-direction knowing they can easily reconfigure the unit if manual operation becomes necessary.

Quality, not compromise.

Muir systems are manufactured with only the finest quality marine grade materials and components. Heavy duty electric motors are series-wound for greater power, faster retrieval and increased dependability. Smaller windlasses incorporate permanent magnet motors. All models feature stainless steel shafts, bronze gears and cone clutches, along with chrome-plated bronze chain gypsies.

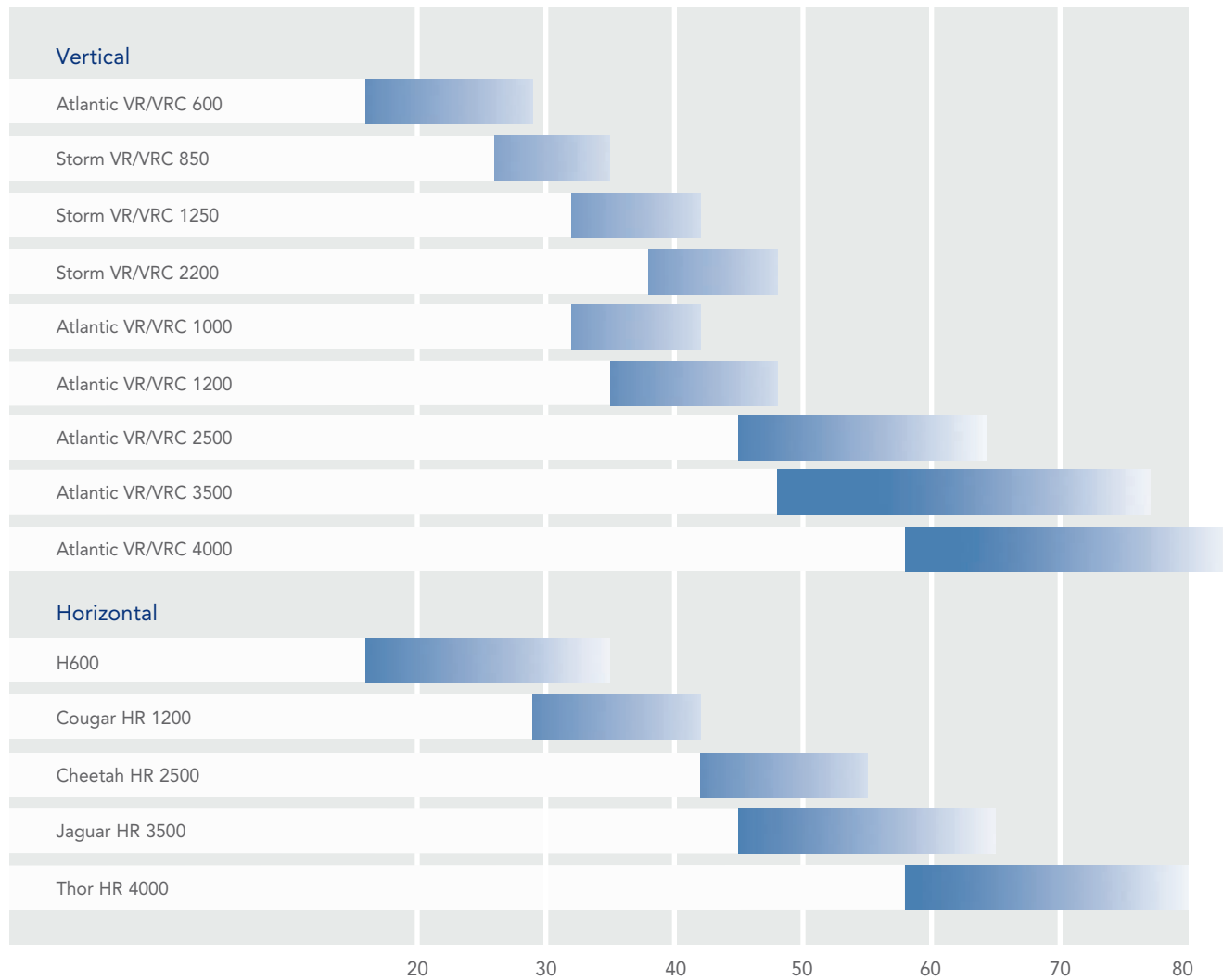
Striving to maintain the highest quality standards, Muir is accredited with ISO 9001 certification. With their superior performance and durability, Muir products have become popular with high speed ferries, military craft, workboats, as well as high quality yacht builders.



Vertical and horizontal models from a leader in anchor technology and innovation.

MUIR WINDLASS SELECTION GUIDE

Muir manufactures a range of windlasses to fit vessels from 16'-83' in length. Use this chart as a basic guide to help determine which type and model is best for you.



MUIR WINDLASSES

PLEASE NOTE: Recommendations for model selection by yacht length are intended for guidance purposes only; actual selection should be made after consulting with competent engineers.

A network of support.

Imtra’s highly-trained regional representatives allow us to maintain close contact with individuals and marine tradespeople, and our knowledgeable in-house service department provides timely repairs and specialized windlass services to our customers (call for details). We are proud to back up our Muir product selection with technical expertise, online services, extensive product and parts availability as well as full warranty service throughout North America.



MUIR WINDLASSES

VERTICAL

Atlantic 600

Vertical rope/chain windlass for boats from 16'-29'.

The 600's radially-adjustable lower unit allows the motor to be positioned in virtually any position, making it easy to fit in small anchor lockers.

Standard Equipment

- Footswitch
- Watertight control box
- Clutch release handle

Features

| | |
|----------------------|---|
| Finish | Chrome |
| Motor | Dual Direction, Permanent Magnet |
| Gearbox | Stainless Worm Drive, Self-Aligning Radially Adjustable |
| Gears | Bronze |
| Mainshaft | Stainless |
| Chainpipe | Fixed |
| Chain Stripper | Chrome with Stainless Steel Band |
| Mounting Hardware | SS Studs, Washers and Nuts |
| Manual Override | N/A |
| Rope Capstan | Optional |
| Extra Deck Clearance | Optional (to 6") |

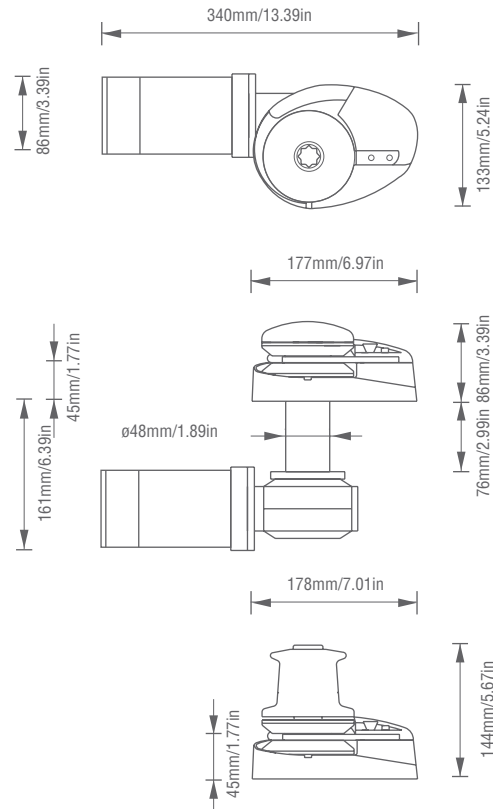
Specifications

| | |
|-------------------------------|------|
| Power Supply | 12V |
| Motor Wattage | 600W |
| Power Rating (lbs.) | 500 |
| Approx. Amp Draw | 80 |
| Max Retrieval Speed (ft/min.) | 80 |
| Chain Size | 1/4" |
| Rope Size | 1/2" |
| Net Weight (lbs.) | 28 |



VRC 600

VR 600



Vertical electric windlasses in low profile and capstan versions.

VERTICAL



SSC850



SS850

Storm 850

Vertical rope/chain windlass for boats from 26'-35'.

The 850's rope/chain management system swallows rodes with ease. Muir's 360° chain stripper and aft-facing pressure finger guide the rode down the chainpipe to ensure trouble-free transitions from chain to rope.

Standard Equipment

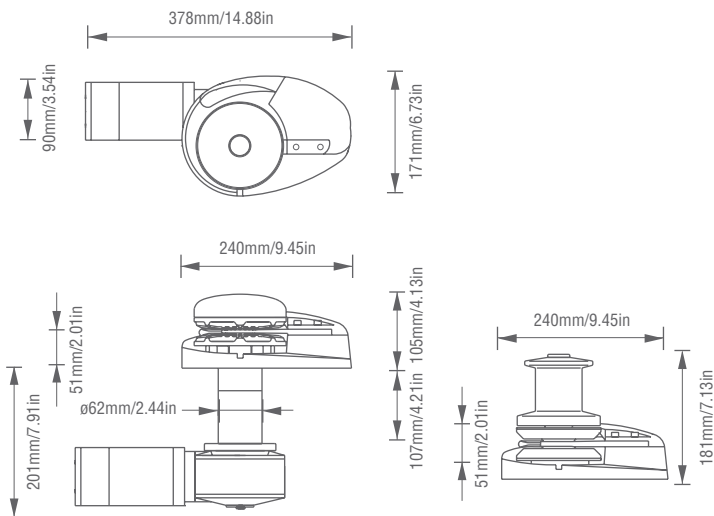
- Footswitch
- Watertight control box
- Clutch release handle

Features

| | |
|-----------------------|---|
| Finish | Stainless Steel |
| Motor | Dual Direction, Permanent Magnet |
| Gearbox | Stainless Worm Drive, Self-Aligning Radially Adjustable |
| Gears | Bronze |
| Mainshaft | Stainless |
| Chainpipe | Swiveling |
| Chain Stripper | Stainless Steel with SS Band |
| Mounting Hardware | SS Studs, Washers and Nuts |
| Manual Override (MOS) | Optional |
| Rope Capstan | Optional |
| Extra Deck Clearance | Optional (to 6") |

Specifications

| | |
|--------------------------------|------|
| Power Supply | 12V |
| Motor Wattage | 600W |
| Power Rating (lbs.) | 500 |
| Approx. Amp Draw | 80 |
| Max Retrieval Speed (ft./min.) | 80 |
| Chain Size | 1/4" |
| Rope Size | 1/2" |
| Net Weight (lbs.) | 28 |



factoid Self-Aligning Gearbox Attachment

This feature allows the gearbox and motor to be installed directly onto the shaft in any radial position and alleviates installation problems due to uneven deck thickness. This is helpful when installing a windlass onto a deck with any camber to the deck surface.

MUIR WINDLASSES

MUIR WINDLASSES

VERTICAL

Storm 1250

Vertical rope/chain windlass for boats from 32'-42'.

Muir's 1250 features a 1000W motor for powerful retrieval and a host of nice touches like its clever swiveling chainpipe, a radially-adjustable gearbox, and mirror-like stainless steel finish.

Standard Equipment

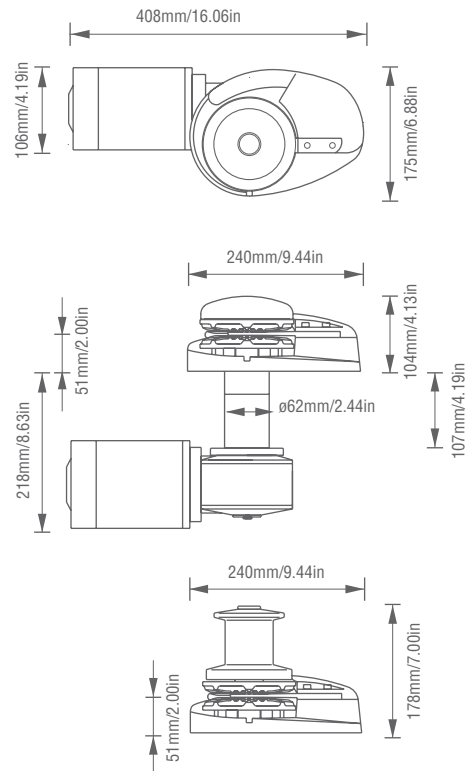
- Footswitch
- Clutch release handle

Features

| | |
|-----------------------|---|
| Finish | Stainless Steel |
| Motor | Dual Direction, Series Wound |
| Gearbox | Stainless Worm Drive, Self-Aligning Radially Adjustable |
| Gears | Bronze |
| Mainshaft | Stainless |
| Chainpipe | Swiveling |
| Chain Stripper | Stainless Steel with SS Band |
| Mounting Hardware | SS Studs, Washers and Nuts |
| Manual Override (MOS) | Optional |
| Rope Capstan | Optional |
| Extra Deck Clearance | Optional (to 6") |

Specifications

| | | |
|--------------------------------|-------------------|-------|
| Power Supply | 12V | 24V |
| Motor Wattage | 1000W | 1000W |
| Power Rating (lbs.) | 1100 | 1100 |
| Approx. Amp Draw | 100 | 60 |
| Max Retrieval Speed (ft./min.) | 48 | 48 |
| Chain Size | 1/4", 5/16", 3/8" | |
| Rope Size | 1/2", 9/16", 5/8" | |
| Net Weight (lbs.) | 40 | 40 |



Vertical electric windlasses in low profile and capstan versions.

VERTICAL



Storm 2200

Vertical rope/chain windlass for boats from 38'-48'.

The 2200 features identical topworks to the 1250 (and 850) yet this powerhouse has the "63" gearbox and 1200W of its bigger brother, the Atlantic 2500.

Standard Equipment

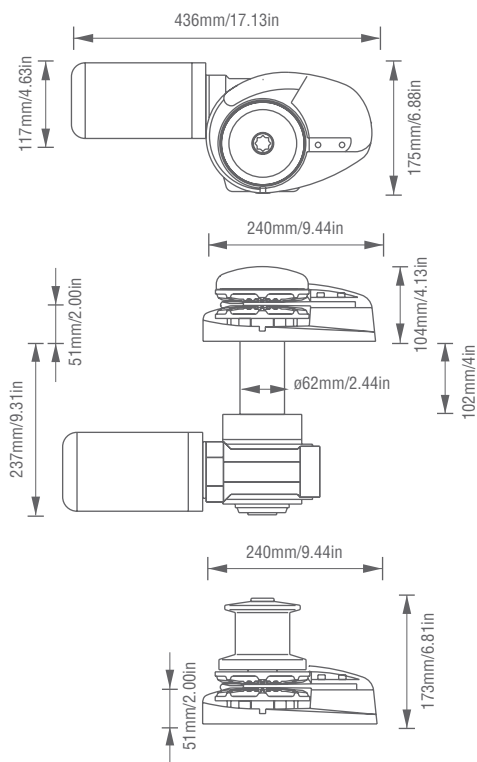
- Footswitch
- Clutch release handle

Features

| | |
|-----------------------|---|
| Finish | Stainless Steel |
| Motor | Dual Direction, Series Wound |
| Gearbox | Stainless Worm Drive, Self-Aligning Radially Adjustable |
| Gears | Bronze |
| Mainshaft | Stainless |
| Chainpipe | Swiveling |
| Chain Stripper | Stainless Steel with SS Band |
| Mounting Hardware | SS Studs, Washers and Nuts |
| Manual Override (MOS) | Optional |
| Rope Capstan | Optional |
| Extra Deck Clearance | Optional (to 6") |

Specifications

| | | |
|--------------------------------|-------------------|-------|
| Power Supply | 12V | 24V |
| Motor Wattage | 1200W | 1200W |
| Power Rating (lbs.) | 2200 | 2200 |
| Approx. Amp Draw | 120 | 75 |
| Max Retrieval Speed (ft./min.) | 50 | 50 |
| Chain Size | 1/4", 5/16", 3/8" | |
| Rope Size | 1/2", 9/16", 5/8" | |
| Net Weight (lbs.) | 55 | 55 |



MUIR WINDLASSES

MUIR WINDLASSES

VERTICAL

Atlantic 1000

Vertical rope/chain windlass for boats from 32'-42'.

The Atlantic 1000 includes a ratcheting manual override system (MORS), a beautiful 2-piece capstan (on VRC models), self-aligning gearbox and deluxe chrome finish.

Standard Equipment

- Footswitch
- Clutch release handle

Features

| | |
|----------------------|---|
| Finish | Stainless Steel |
| Motor | Dual Direction, Series Wound |
| Gearbox | Stainless Worm Drive, Self-Aligning Radially Adjustable |
| Gears | Bronze |
| Mainshaft | Stainless |
| Chainpipe | Swiveling |
| Chain Stripper | Stainless Steel with Stainless Steel Band |
| Mounting Hardware | SS Studs, Washers and Nuts |
| Manual Override | Standard |
| Rope Capstan | Optional |
| Extra Deck Clearance | Optional (to 6") |

Specifications

| | | |
|--------------------------------|-------------------|-------|
| Power Supply | 12V | 24V |
| Motor Wattage | 1000W | 1000W |
| Power Rating (lbs.) | 1000 | 1000 |
| Approx. Amp Draw | 100 | 60 |
| Max Retrieval Speed (ft./min.) | 48 | 48 |
| Chain Size | 1/4", 5/16", 3/8" | |
| Rope Size | 1/2", 9/16", 5/8" | |
| Net Weight (lbs.) | 46 | 46 |



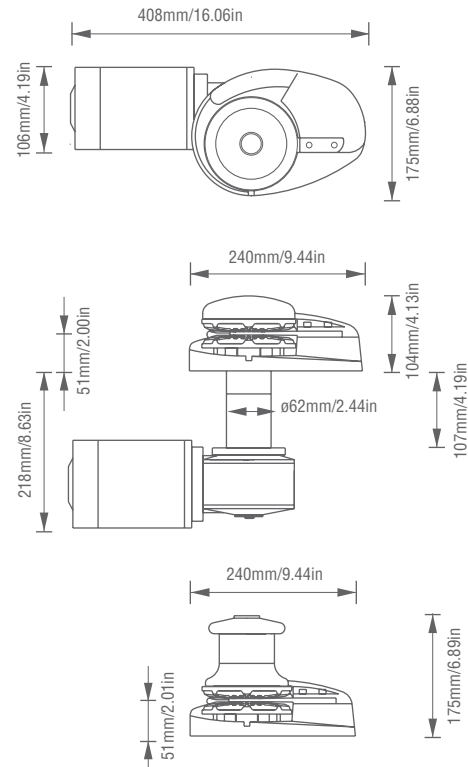
Photo: Tiara Yachts



VR 1000



VRC 1000



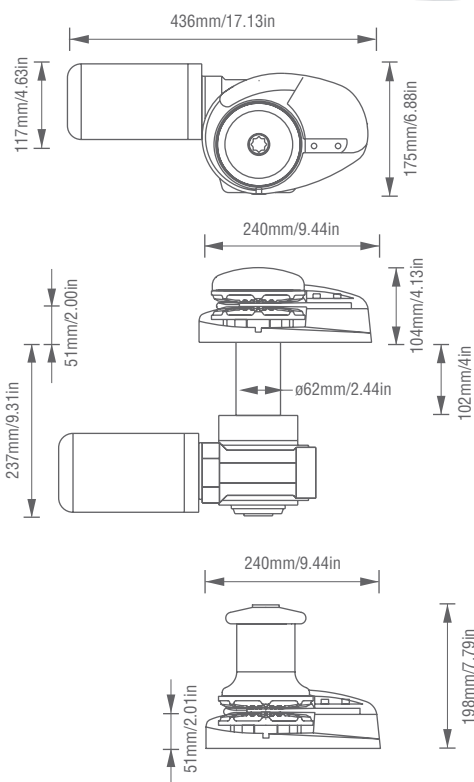
Vertical electric windlasses in low profile and capstan versions.

VERTICAL



VRC 1200

VR 1200



Atlantic 1200

Vertical rope/chain windlass for boats from 35'-48'.

The Atlantic 1200 takes all the features of the Atlantic 1000 and adds a larger 1200W motor to the package. VRC1200's have a slightly taller rope drum to accept larger anchor line.

Standard Equipment

- Footswitch
- Clutch release handle

Features

| | |
|----------------------|---|
| Finish | Chrome |
| Motor | Dual Direction, Series Wound |
| Gearbox | Stainless Worm Drive, Self-Aligning Radially Adjustable |
| Gears | Bronze |
| Mainshaft | Stainless |
| Chainpipe | Swiveling |
| Chain Stripper | Chrome with Stainless Steel Band |
| Mounting Hardware | SS Studs, Washers and Nuts |
| Manual Override | Standard |
| Rope Capstan | Optional |
| Extra Deck Clearance | Optional (to 6") |

Specifications

| | 12V | 24V |
|--------------------------------|-------------------|-------|
| Power Supply | 12V | 24V |
| Motor Wattage | 1200W | 1200W |
| Power Rating (lbs.) | 1200 | 1200 |
| Approx. Amp Draw | 120 | 75 |
| Max Retrieval Speed (ft./min.) | 48 | 48 |
| Chain Size | 1/4", 5/16", 3/8" | |
| Rope Size | 1/2", 9/16", 5/8" | |
| Net Weight (lbs.) | 46 | 53 |

MUIR WINDLASSES

Swivel Chainpipe

All Muir vertical windlasses larger than the Atlantic 600 have a unique swiveling chainpipe. A thumbscrew bolt is easily removed to allow the chainpipe to swivel sideways offering access to the chainpipe hole to the anchor locker.

factoid

MUIR WINDLASSES

VERTICAL

Atlantic 2500/3500

Vertical rope/chain windlass for boats from 45'-77'.

The 2500 and 3500 windlasses share the same topworks and "63" gearbox. The 2500 is driven by a 1200W motor; the 3500 by a 1500W motor. Both units accept rope/chain combination or all chain rodes.

Standard Equipment

- Footswitch
- Clutch release handle

Features

| | |
|----------------------|---|
| Finish | Chrome |
| Motor | Dual Direction, Series Wound |
| Gearbox | Stainless Worm Drive, Self-Aligning Radially Adjustable |
| Gears | Bronze |
| Mainshaft | Stainless |
| Chainpipe | Swiveling |
| Chain Stripper | Chrome with Stainless Steel Band |
| Mounting Hardware | SS Studs, Washers and Nuts |
| Manual Override | Optional |
| Rope Capstan | Optional |
| Extra Deck Clearance | Optional (to 6") |

Specifications

| | | |
|-------------------------------|--------------------------|-----------------------|
| Power Supply | 12V or 24V | 12V or 24V |
| Motor Wattage | 1200W | 1500W |
| Power Rating (lbs.) | 2500 | 3500 |
| Approx. Amp Draw | 120 (12V) 75 (24V) | 150 (12V) 85 (24V) |
| Max Retrieval Speed (ft/min.) | 44 | 44 |
| Chain Size | 5/16", 3/8", 7/16", 1/2" | |
| Rope Size | 9/16", 5/8", 3/4" | |
| Net Weight (lbs.) | 96 | 101 |

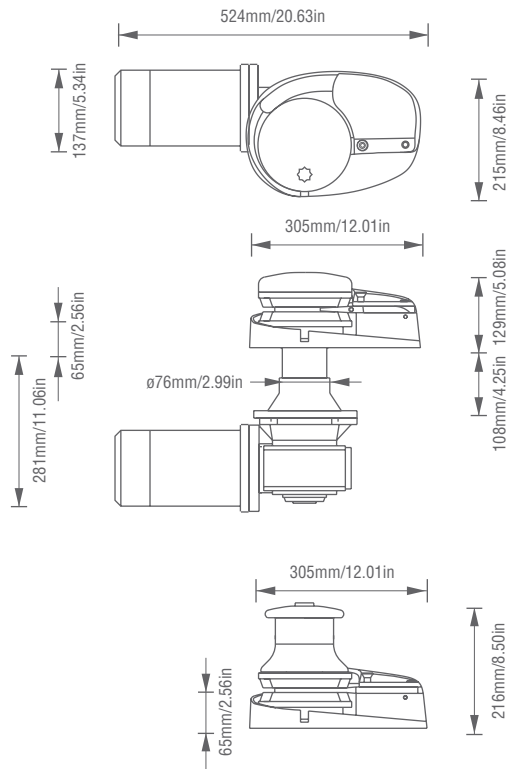


Photo: Fleming Yachts



VR 2500/3500

VRC 2500/3500



Vertical electric windlasses for larger yachts.

VERTICAL

Atlantic 4000

Vertical rope/chain windlass for boats from 58'-83'.

The 4000 is driven by a 2000W motor to lift even the heaviest loads. The rope drum on VRC models is taller to accept the larger anchor and docking lines of large yachts. Hydraulic versions are also available.

Standard Equipment

- Footswitch
- Clutch release handle

Features

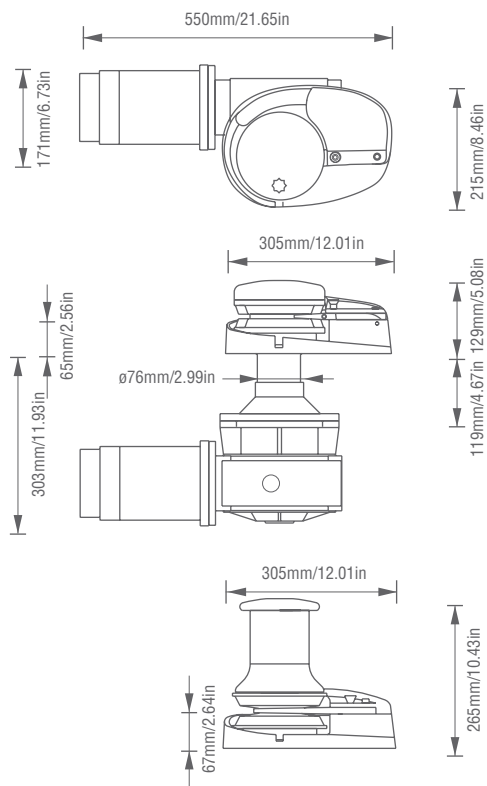
| | |
|------------------------|---|
| Finish | Chrome |
| Motor | Dual Direction, Series Wound |
| Gearbox | Stainless Worm Drive, Self-Aligning Radially Adjustable |
| Gears | Bronze |
| Mainshaft | Stainless |
| Chainpipe | Swiveling |
| Chain Stripper | Chrome with Stainless Steel Band |
| Mounting Hardware | SS Studs, Washers and Nuts |
| Manual Override (MORS) | Optional |
| Rope Capstan | Optional |
| Extra Deck Clearance | Optional (to 6") |

Specifications

| | |
|--------------------------------|-------------------|
| Power Supply | 24V or Hydraulic |
| Motor Wattage | 2000W |
| Power Rating (lbs.) | 4000 |
| Approx. Amp Draw | 70 |
| Max Retrieval Speed (ft./min.) | 44 |
| Chain Size | 3/8", 7/16", 1/2" |
| Rope Size | 9/16", 5/8", 3/4" |
| Net Weight (lbs.) | 119 |



VR 4000



MUIR WINDLASSES

factoid Mirror Image Windlasses

Muir offers mirror image versions of its 2500, 3500 and 4000 verticals. For large yachts fitting a pair of vertical windlasses, the primary drive systems are reversed on the left-hand model so rodes rotate in opposite directions (clockwise on starboard unit; counter-clockwise on port windlasses).

MUIR WINDLASSES

HORIZONTAL

Cougar

Horizontal chain, rope or rope/chain windlass for boats from 30'-38'.

Ratcheting manual recovery, beautiful white housing, bushed mounting points, and optional rope/chain management system are a few of the best features of this popular windlass.

Standard Equipment

- Footswitch
- Clutch/manual operation handle

Features

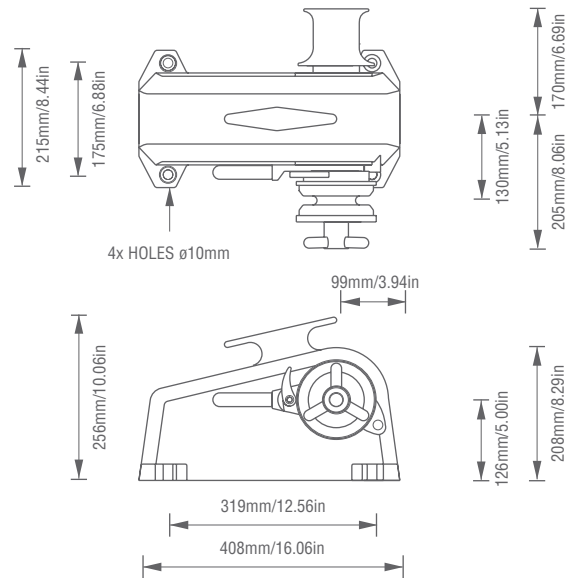
| | |
|----------------------|------------------------------|
| Finish | White |
| Motor | Dual Direction, Series Wound |
| Gearbox | Stainless Worm Drive |
| Gears | Bronze |
| Mainshaft | Stainless |
| Chainpipe | Optional |
| Chain Stripper | Stainless |
| Mounting Hardware | Insulated Bushings Only |
| Manual Override | Standard |
| Rope Capstan | Standard |
| Extra Deck Clearance | N/A |

Specifications

| | | |
|--------------------------------|-------------------|-------|
| Power Supply | 12V | 24V |
| Motor Wattage | 1000W | 1000W |
| Power Rating (lbs.) | 1200 | 1200 |
| Approx. Amp Draw | 100 | 60 |
| Max Retrieval Speed (ft./min.) | 46 | 46 |
| Chain Size | 1/4", 5/16", 3/8" | |
| Rope Size | 1/2", 9/16", 5/8" | |
| Net Weight (lbs.) | 55 | 55 |

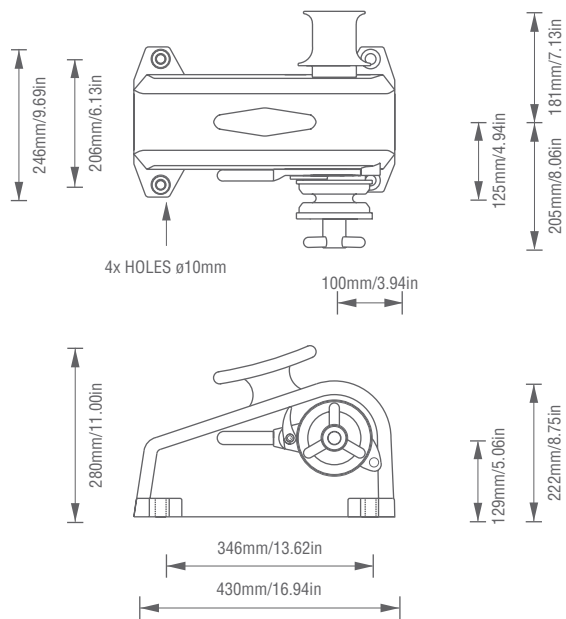


Photo: CW Hood 30



Horizontal electric windlasses for boats from 30' to 45'.

HORIZONTAL



Cheetah

Horizontal windlass for yachts from 38'-45'.

This rugged unit is fitted with a starboard chainwheel and port capstan as standard. Dual gypsy models are available upon request.

Standard Equipment

- Footswitch
- Chainpipe
- Clutch/manual operation handle
- Optional dual gypsy configuration

Features

| | |
|----------------------|------------------------------|
| Finish | White |
| Motor | Dual Direction, Series Wound |
| Gearbox | Stainless Worm Drive |
| Gears | Bronze |
| Mainshaft | Stainless |
| Chainpipe | Standard |
| Chain Stripper | Standard with Chainpipe |
| Mounting Hardware | Insulated Bushings Only |
| Manual Override | Standard |
| Rope Capstan | Standard |
| Extra Deck Clearance | N/A |

Specifications

| | | |
|--------------------------------|--------------------------|-------|
| Power Supply | 12V | 24V |
| Motor Wattage | 1200W | 1200W |
| Power Rating (lbs.) | 2500 | 2500 |
| Approx. Amp Draw | 120 | 75 |
| Max Retrieval Speed (ft./min.) | 48 | 48 |
| Chain Size | 5/16", 3/8", 7/16", 1/2" | |
| Rope Size | 9/16", 5/8", 3/4" | |
| Net Weight (lbs.) | 79 | 79 |

MUIR WINDLASSES

Dual Gypsies

factoid

Many bluewater yachts are configured to deploy two bow anchors. If both are to be primarily all chain systems, a windlass with dual gypsies makes the most sense. Each gypsy can be engaged (or disengaged) to allow individual operation of each chain rode. Imtra offers dual gypsy models from both Muir and Lofrans.

MUIR WINDLASSES

HORIZONTAL

Jaguar

Horizontal windlass for yachts from 45'-52'.

Jaguar features a 1500W motor for high-powered performance. Its size makes it a good choice for cruising boats with high sided bulwarks and divided chain lockers.

Standard Equipment

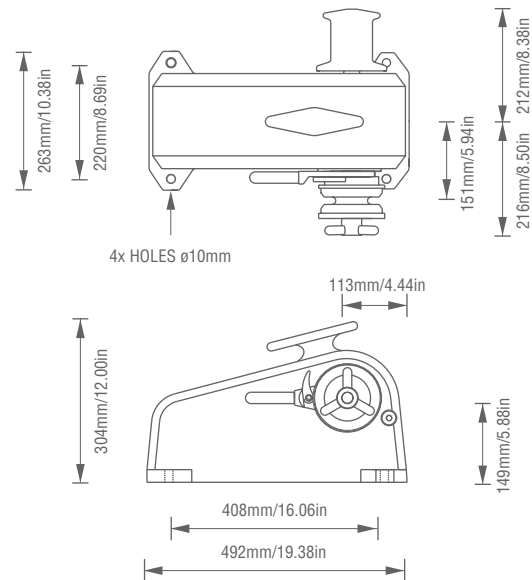
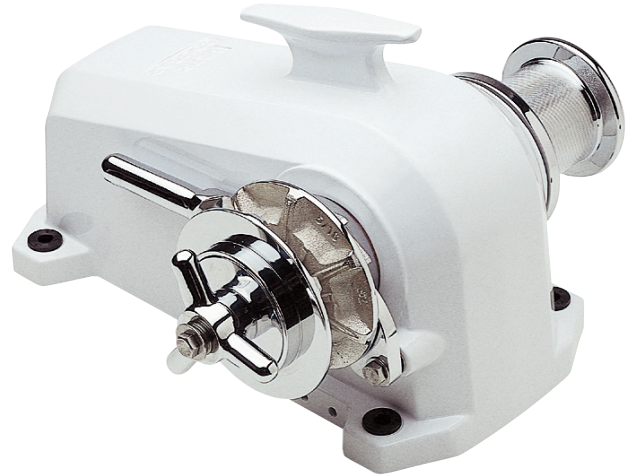
- Footswitch
- Chainpipe
- Clutch/manual operation handle
- Optional dual gypsy configuration

Features

| | |
|----------------------|------------------------------|
| Finish | White |
| Motor | Dual Direction, Series Wound |
| Gearbox | Stainless Worm Drive |
| Gears | Bronze |
| Mainshaft | Stainless |
| Chainpipe | Standard |
| Chain Stripper | Standard with Chainpipe |
| Mounting Hardware | Insulated Bushings Only |
| Manual Override | Standard |
| Rope Capstan | Standard |
| Extra Deck Clearance | N/A |

Specifications

| | | |
|--------------------------------|--------------------------|-------|
| Power Supply | 12V | 24V |
| Motor Wattage | 1500W | 1500W |
| Power Rating (lbs.) | 3500 | 3500 |
| Approx. Amp Draw | 150 | 85 |
| Max Retrieval Speed (ft./min.) | 48 | 48 |
| Chain Size | 5/16", 3/8", 7/16", 1/2" | |
| Rope Size | 9/16", 5/8", 3/4" | |
| Net Weight (lbs.) | 128 | 128 |



Horizontal electric windlasses for boats from 45' to 60'.

HORIZONTAL

Thor

Horizontal windlass for yachts from 50'- 60'.

Available with DC electric or hydraulic motors that will easily retrieve chain up to 5/8" with speed. Thor is especially well-suited for heavy-displacement cruising yachts.

Standard Equipment

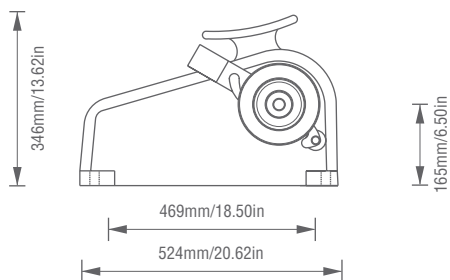
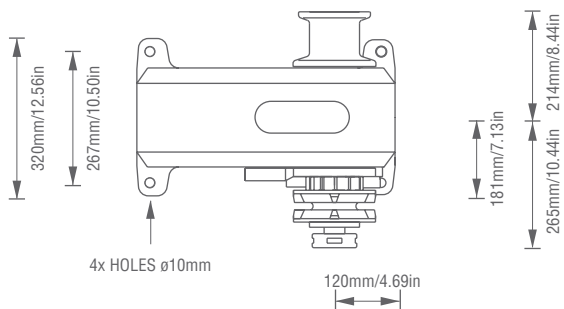
- Footswitch
- Chainpipe
- Clutch/manual operation handle
- Optional dual gypsy configuration

Features

| | |
|----------------------|------------------------------|
| Finish | White |
| Motor | Dual Direction, Series Wound |
| Gearbox | Stainless Worm Drive |
| Gears | Bronze |
| Mainshaft | Stainless |
| Chainpipe | Standard |
| Chain Stripper | Standard with Chainpipe |
| Mounting Hardware | Insulated Bushings Only |
| Manual Override | Standard |
| Rope Capstan | Standard |
| Extra Deck Clearance | N/A |

Specifications

| | | |
|--------------------------------|-------------------------|-------|
| Power Supply | 12V or 24V | 24V |
| Motor Wattage | 1500W | 2000W |
| Power Rating (lbs.) | 4000 | 4500 |
| Approx. Amp Draw | 150 (12V) 85 (24V) | 120 |
| Max Retrieval Speed (ft./min.) | 44 | 44 |
| Chain Size | 3/8", 7/16", 1/2", 5/8" | |
| Rope Size | 5/8", 3/4" | |
| Net Weight (lbs.) | 140 | 140 |



MUIR WINDLASSES

SWITCHGEAR

Switchgear from Imtra makes anchoring easier and safer.

The right switchgear enhances any windlass installation and makes anchoring safer and easier.

Imtra has the high quality switchgear you're looking for, with



Photo: Sea Ray, Inc.

proven designs made from the best materials. Our products include footswitches, hand-helds, simple and intelligent control panels, breakers, and control boxes.

Best of all, these choices allow you to customize your installation to get the most out of your anchoring system.



Photo: Carver Yachts



High-Amperage Footswitches

These covered or uncovered footswitches handle full windlass loads without an external solenoid or control box. The uncovered version offers a chrome bezel. The covered model (available in white or black) is hinged to fold flat to the deck when in use; when not in use, the cover closes to prevent accidental operation.

- 200 Amp continuous rating (@12VDC)
- 600 Amp "make or break"
- 4" (100mm) diameter
- 8mm studs for wiring connections
- Supplied with fasteners
- Contact activated

- SPA-10500K Uncovered Footswitch
- SPA-10502K Covered Footswitch, Black
- SPA-10504K Covered Footswitch, White

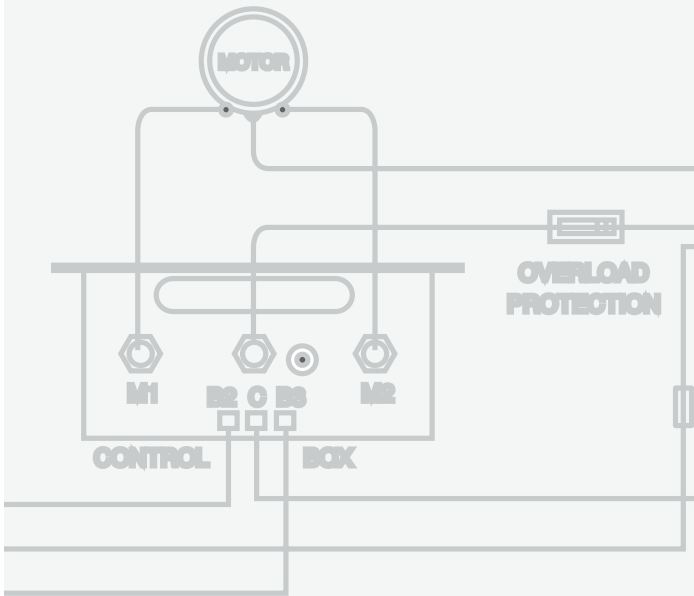


Lofrans Low-Amperage Footswitches

These covered, electronic footswitches need only a small 1/4" opening in the deck for wires to pass through, making them perfect for compact installations. Requires an external solenoid or control box.

- Hinged cover
- Choice of grey or white covers
- Boot up (black) or down (red)
- 'Donut' style cover allows fingertip operation
- Supplied with fasteners
- Contact activated

- LWP950G Low-Amp Footswitch
Grey Cover, Black Boot (Up)
- LWP951G Low-Amp Footswitch
Grey Cover, Red Boot (Down)
- LWP950W Low-Amp Footswitch
White Cover, Black Boot (Up)
- LWP951W Low-Amp Footswitch
White Cover, Red Boot (Down)



Footswitches, windlass control boxes, magnetic and thermal circuit breakers.



Windlass Control Boxes

Watertight and pre-wired, our dual-solenoid control boxes are available for 2/4 or 3-wire windlass motors. Rated for continuous duty to 150 Amps (surge to 500 Amps).

- Control Boxes for 3-Wire Motors
- Control Boxes for 2- and 4-Wire Motors

| | |
|-----------|---|
| SPA-10700 | Watertight Control Box, 12V, 700 to 1700W |
| SPA-10724 | Watertight Control Box, 24V, 700 to 1700W |
| SPA-10824 | Watertight Control Box, 24V, 700 to 2300W |
| SPA-10697 | Watertight Control Box, 12V, 500 to 1300W |
| SPA-10696 | Watertight Control Box, 24V, 500 to 1300W |



Quick™ Low-Amperage Footswitches

These covered, electronic footswitches need only a small 1/4" opening in the deck for wires to pass through, making them perfect for compact installations. Requires an external solenoid or control box.

- Hinged cover
- Choice of black or white covers
- Boot up (red) or down (grey)
- 'Donut' style cover allows fingertip operation
- Supplied with fasteners
- Micro switch activated

| | |
|------------|---|
| SPA-10510 | Low-Amp Footswitch Black Cover, Grey Boot (Down) |
| SPA-10511 | Low-Amp Footswitch Black Cover, Red Boot (Up) |
| SPA-10510W | Low-Amp Footswitch White Cover, Grey Boot (Down) |
| SPA-10511W | Low-Amp Footswitch White Cover, Red Boot (Up) |

Thermal Breakers

We utilize popular Bussman® breakers for those desiring a thermal breaker. Available in 50, 70, 110 and 150A sizes, these breakers are offered in surface-mount or thru-bulkhead versions. Thru-Bulkhead models include a faceplate and install with a simple 2 1/8" holesaw cutout. Thru-Bulkhead models have an LED indicator light. All are IP66 for use in wet locations. Connections are 5/16" to accept large terminal lugs. All accept input voltage up to 48VDC.

| | |
|---------------|--|
| SPA-187050L | 50 Amp, Thru-Bulkhead w/12V LED Indicator |
| SPA-187070L | 70 Amp, Thru-Bulkhead w/12V LED Indicator |
| SPA-187110L | 110 Amp, Thru-Bulkhead w/12V LED Indicator |
| SPA-187150L | 150 Amp, Thru-Bulkhead w/12V LED Indicator |
| SPA-187LAMP24 | 24V LED Indicator Light |
| SPA-187050F | 50 Amp, Surface Mount |
| SPA-187070F | 70 Amp, Surface Mount |
| SPA-187110F | 110 Amp, Surface Mount |
| SPA-187150F | 150 Amp, Surface Mount |



Simple Solenoid

Continuous duty solenoid 300Amp/12V to control one windlass operation (up or down).

| | |
|-----------|-------------------------------|
| SPA-10600 | Continuous Duty Solenoid, 12V |
|-----------|-------------------------------|

SWITCHGEAR



Photo: Sabre Yachts



AutoAnchor™ 560 Rode Counter and Windlass Controller

This panel mounted AutoAnchor offers stress-free anchoring at the touch of a button. The 560 is suitable for DC electric windlasses using all chain or rope/chain rode, as well as hydraulic or AC-powered windlasses using all chain rode.

- Graphic LCD screen featuring intuitive user interface for simple operation
- Adjustable backlit display in feet, meters or fathoms
- Preset stopping point on retrieval
- One-touch function to deploy and retrieve a preset length of rode
- Displays windlass speed and direction, plus battery voltage
- Safety lock to help protect against accidental windlass deployment
- Logs windlass operation hours to help ensure regular windlass maintenance

SPA-AA560 AA560 Rode Counter and Windlass Control, Black
 SPA-AA560-G AA560 Rode Counter and Windlass Control, Grey



Toggle Up/Down Panels

Features a momentary switch for safe windlass operation. Rubber toggle cover ensures trouble-free performance in exposed locations. Size: 2" x 3 1/2"

SPA-10550 Panel Mount Up/Down Remote



AutoAnchor 150 Rode Counter

This panel mount rode counter is designed for DC electric windlasses using an all chain or rope/chain rode. Also suitable for hydraulic or AC-powered windlasses using all chain rode. The large, adjustable LCD display lets you see exactly how much rode has been released (in feet or meters). Kit includes one console unit, one sensor and one magnet.

- Easy to install and set up
- Beeps to warn operator when the anchor is 4 feet from stowing
- Adjustable red backlighting for easy night viewing
- Matches diameter of common marine instrument gauges
- Supports multiple displays

SPA-AA150 AutoAnchor 150 Rode Counter



Sensor Cables

Sensor cables to fit AA560 and AA150 rode counters.

- SPA-AA9500 Sensor Cable, 6.5m (21')
- SPA-AA9501 Sensor Cable, 10m (32')
- SPA-AA9502 Sensor Cable, 15m (49')
- SPA-AA9503 Sensor Cable, 20m (65')
- SPA-AA9504 Sensor Cable, 25m (82')
- SPA-AA9110 Sensor Holder for Horizontal Windlasses

Remote controls and chain counters for windlasses.



AutoAnchor Handheld Remote Controls

Handheld wireless remote controls from AutoAnchor. Each is supplied with marine plug, socket and cover, stowage bracket, and 7' spiral cord. Universal power supply (12 or 24VDC).

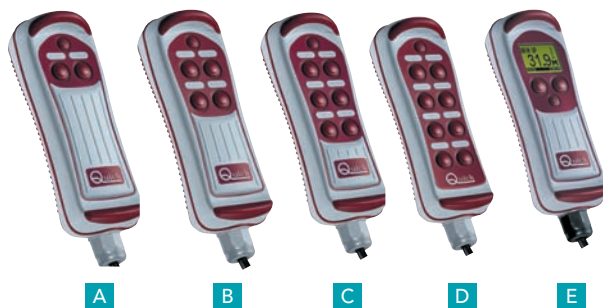
- A** 2-Function AutoAnchor Handheld Remote
SPA-AA9207 2-Function with 7' Spiral Cord
- B** 4-Function AutoAnchor Handheld Remote
SPA-AA9210 4-Function with 7' Spiral Cord
- C** 2-Function AutoAnchor Wired Handheld Remote with Chain Counter
SPA-AA9209 2-Function Wired Chain Counter (Complete Kit)

AutoAnchor 710 Handheld Wireless Remote

Handheld wireless remote control for windlasses using all chain or rope/chain rodes. This remote is shockproof and waterproof (it floats) with an LED backlit display. Complete kit includes hand remote, base station, magnet and sensor, holder and cover.

- Full Graphic LCD screen featuring intuitive user interface for simple operation
- Adjustable backlit display in feet, meters or fathoms
- Logs windlass operation hours to help ensure regular windlass maintenance
- Displays signal strength and battery level
- Ergonomic design with wrist strap
- 12 or 24VDC

- SPA-AA9408 AA710 Complete Handheld Windlass Remote
- SPA-AA9400 AA710 Handheld Remote only
- SPA-AA9405 AA710 Base Station only
- SPA-AA9403 AA710 Optional Antenna (often required on steel or carbon fiber boats)



Quick™ Handheld Remote Controls

Imtra offers the latest in handheld remote controls from Quick. Compact and watertight, these multi-purpose controls are manufactured using only the highest quality materials and components. Available in 2-, 4-, 6- or 8-function models, with or without an integrated LED lamp (shown below). Each is supplied with marine plug, socket and cover, stowage bracket, and 7' spiral cord. Universal power supply (12 or 24VDC).

- A** 2-Function Quick Handheld Remotes
SPA-HRC1002 2-Function with 7' Spiral Cord
SPA-HRC1002L 2-Function with 7' Spiral Cord & LED Lamp
- B** 4-Function Quick Handheld Remote
SPA-HRC1004 4-Function with 7' Spiral Cord
- C** 6-Function Quick Handheld Remote
SPA-HRC1006 6-Function with 7' Spiral Cord
- D** 8-Function Quick Handheld Remote
SPA-HRC1008 8-Function with 7' Spiral Cord
- E** 2-Function Quick Handheld Remote w/Chain Counter
SPA-CHC1102M 2-Function with Chain Counter (Up/Down)



Integrated LED Light

Imtra's range of Quick remote controls are the only multi-purpose handheld remotes available with an optional Integrated LED Lamp Torch for safer and more controlled operation in the dark. All versions are IP67 waterproof.



ANCHOR CHAIN & RODES

Imtra has the anchor chain, line and rodes that you need.

Imtra offers popular brands of anchor chain in three configurations: Grade 43 (G43) High-Tensile, BBB Grade 30 (3B), and Stainless Steel. G43 and stainless steel meet



ISO specifications. Anchor chain is available by the full drum, the half-drum or by the foot. Longer lengths may be special ordered on request. To meet your individual specifications, Imtra will create a

customized rope/chain combination. We also stock the most popular combination rodes, shown on these pages.



G43 High-Tensile Anchor Chain

ACCO® Grade 43 (G43) hot-galvanized, high-tensile has become an industry standard, combining high strength in a short-link chain that runs easily in anchor windlass gypsies. Available by the foot from 1/4" - 3/8"; in half-drums or in full drums from 1/4" - 5/8".



BBB Grade 30 Anchor Chain

Although not as strong as the G43, ACCO's Grade 30 BBB-chain (3B) also runs well on many windlasses for a lesser price. Available by the foot in 5/16" and 3/8"; in half-drum or full drums in 5/16", 3/8" and 1/2".

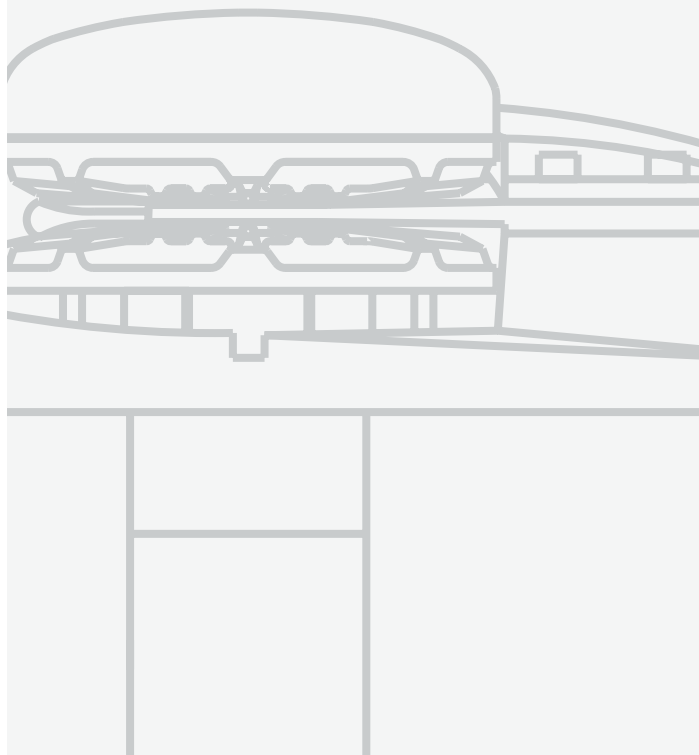


Stainless Steel (SS)

Imtra's 316 stainless steel chain makes an attractive and functional alternative to galvanized chain, especially on rope/chain combination rodes. Available by the foot from 1/4" - 3/8"; in half drums or in full drums from 1/4" - 5/8".

Oversize Links

Imtra can order custom lengths of ACCO G43 chain (5/16" - 5/8") complete with oversize links on the end to accept larger, stronger shackles. All are made to special order specifications. Contact Imtra for more information.



Anchor chain and custom or pre-made rodes to meet your requirements.

CHAIN SELECTION GUIDE


Use this chart as a basic guide to help determine which chain size and type is best for you.

| | Item No. Per Foot | Item No. Half-Drum | Item No. Full-Drum | Chain Size | Working Load | Weight Per 100' | Full Drum Length | Drum Weight | Inside Dimensions Length | Width |
|-----|-------------------|--------------------|--------------------|------------|--------------|-----------------|------------------|-------------|--------------------------|-------|
| G43 | AC40402 | AC40402H | AC40402F | 1/4" | 2600 lbs. | 79 lbs. | 800' | 632 lbs. | 0.84" | 0.41" |
| | AC40502 | AC40502H | AC40502F | 5/16" | 3900 lbs. | 116 lbs. | 550' | 638 lbs. | 1.03" | 0.51" |
| | AC40602 | AC40602H | AC40602F | 3/8" | 5400 lbs. | 153 lbs. | 400' | 612 lbs. | 1.22" | 0.59" |
| | AC40702 | AC40702H | AC40702F | 7/16" | 7200 lbs. | 216 lbs. | 300' | 648 lbs. | 1.40" | 0.65" |
| | AC40802 | AC40802H | AC40802F | 1/2" | 9200 lbs. | 271 lbs. | 200' | 542 lbs. | 1.59" | 0.76" |
| | AC41002 | AC41002H | AC41002F | 5/8" | 13000 lbs. | 399 lbs. | 150' | 599 lbs. | 1.79" | 0.90" |
| BBB | AC60502 | AC60502H | AC60502F | 5/16" | 1950 lbs. | 118 lbs. | 550' | 649 lbs. | 1.00" | 0.50" |
| | AC60602 | AC60602H | AC60602F | 3/8" | 2750 lbs. | 167 lbs. | 400' | 668 lbs. | 1.09" | 0.62" |
| | AC60802 | AC60802H | AC60802F | 1/2" | 4750 lbs. | 287 lbs. | 200' | 574 lbs. | 1.34" | 0.75" |
| SS | AC80402 | AC80402H | AC80402F | 1/4" | 2930 lbs. | 77 lbs. | 800' | 616 lbs. | 0.84" | 0.41" |
| | AC80502 | AC80502H | AC80502F | 5/16" | 4250 lbs. | 112 lbs. | 550' | 616 lbs. | 1.03" | 0.51" |
| | AC80602 | AC80602H | AC80602F | 3/8" | 5860 lbs. | 157 lbs. | 400' | 628 lbs. | 1.22" | 0.59" |
| | AC80802 | AC80802H | AC80802F | 1/2" | 9465 lbs. | 249 lbs. | 200' | 498 lbs. | 1.59" | 0.76" |
| | AC81002 | AC81002H | AC81002F | 5/8" | 13400 lbs. | 430 lbs. | 150' | 645 lbs. | 1.79" | 0.90" |

Custom & Pre-Made Rodes

Imtra assembles custom anchor rodes to meet our customers' requirements. Working together with New England Ropes, we have created a proprietary anchor line that is durable, strong and works well in rope/chain anchor windlasses. With ropes from 1/2"-3/4" in diameter and ACCO chain from 1/4"-3/8" in size, we can make the perfect rode for your boat. In addition to our custom program, we stock the most popular combinations of rope and chain.

ANCHOR CHAIN & RODES

| | |
|--|---|
| <p>Pre-Made Rodes with 1/4" G43 Chain</p> <p>SPA-11H8A R/C Rode, 8' x 1/4" HT Chain spliced to 150' x 1/2" Line</p> <p>SPA-11H15A R/C Rode, 15' x 1/4" HT Chain spliced to 200' x 1/2" Line</p> <p>SPA-11H20C R/C Rode, 20' x 1/4" HT Chain spliced to 100' x 1/2" Line</p> <p>SPA-11H300C R/C Rode, 30' x 1/4" HT Chain spliced to 300' x 1/2" Line</p> |  |
| <p>Pre-Made Rodes with 5/16" G43 Chain</p> <p>SPA-12H6B R/C Rode, 6' x 5/16" HT Chain spliced to 150' x 1/2" Line</p> <p>SPA-12H6A R/C Rode, 6' x 5/16" HT Chain spliced to 150' x 9/16" Line</p> <p>SPA-12H15A R/C Rode, 15' x 5/16" HT Chain spliced to 200' x 9/16" Line</p> <p>SPA-12H15C R/C Rode, 15' x 5/16" HT Chain spliced to 100' x 9/16" Line</p> <p>SPA-12H25A R/C Rode, 25' x 5/16" HT Chain spliced to 200' x 9/16" Line</p> <p>SPA-12H25B R/C Rode, 25' x 5/16" HT Chain spliced to 200' x 5/8" Line</p> <p>SPA-12H30C R/C Rode, 30' x 5/16" HT Chain spliced to 300' x 9/16" Line</p> <p>SPA-12H50B R/C Rode, 50' x 5/16" HT Chain spliced to 200' x 5/8" Line</p> | |
| <p>Pre-Made Rodes with 3/8" G43 Chain</p> <p>SPA-13H30B R/C Rode, 30' x 3/8" HT Chain spliced to 200' x 3/4" Line</p> <p>SPA-13H50D R/C Rode, 50' x 3/8" HT Chain spliced to 250' x 3/4" Line</p> | |
| <p>Pre-Made Rodes with Stainless Steel Chain</p> <p>SPA-12S150A R/C Rode, 15' x 5/16" SS Chain spliced to 150' x 1/2" Line</p> <p>SPA-12S20A R/C Rode, 20' x 5/16" SS Chain spliced to 150' x 1/2" Line</p> <p>SPA-13S25B R/C Rode, 25' x 3/8" SS Chain spliced to 200' x 5/8" Line</p> | |

ACCESSORIES

Put the finishing touches on your system with the right anchoring accessories.

Imtra has collected a variety of high quality products to complete your anchoring system. These items were



Photo: Shutterstock

selected specifically to work with Imtra's Lofrans and Muir windlass lines, yet will work equally well with most other anchoring systems. From chainstoppers to stainless steel anchor swivels, our full range of anchoring accessories will

add to your boating safety, convenience and enjoyment.

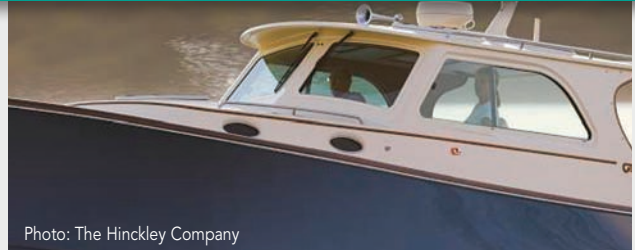


Photo: The Hinckley Company



Stainless Steel Chainstopper

Our stainless steel chainstopper accommodates chain from 1/4" - 3/8", features a removal pawl (with lanyard) and safely works with loads of 5,000 lbs. The chainstopper mounts with two 3/8" fasteners (not included) and has a footprint that is 2 3/4" - 3 1/8".

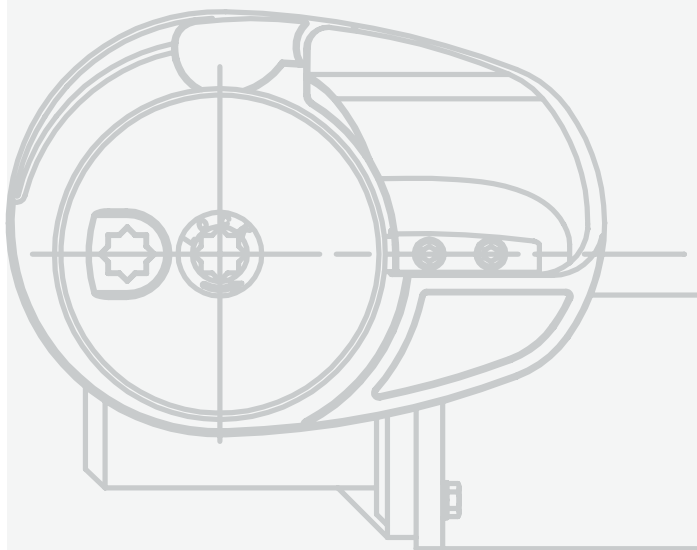
SPA-6988S Stainless Steel Chainstopper for 1/4" - 3/8"



Polished Stainless Chainstoppers

Imtra offers the Muir modular chainstopper system for larger applications. These stoppers are available in their base form but can be upgraded to include a Devil's Claw assembly with the optional conversion kits. Available in two sizes: 5/16" - 3/8" or 7/16" - 1/2". Larger sizes available by special order.

- MCLK316F10 Muir Chainstopper for 5/16" - 3/8" Chain
- MCLK316F13 Muir Chainstopper for 7/16" - 1/2" Chain
- MDCKIT10 Devil's Claw Conversion Kit for MCLK31610A
- MDCKIT13 Devil's Claw Conversion Kit for MCLK31613A



Chainstoppers, anchor swivels, snubbers, chain hooks and chain markers.



Anchor Swivels

Our anchor swivels are constructed of rugged 18-8 stainless steel that is buffed to a polished finish. Their streamlined design ensures free running through bow rollers and chocks. The swivel also assists in the alignment of the anchor shaft into the bow roller. Use the chart below to find the size swivel that is best for your application.

| Item No. | Description | Working Load | Chain Size | Spread Between Eyes: | | Pin Diameter: | |
|----------|----------------|--------------|---------------|----------------------|------------|---------------|------------|
| | | | | Chain End | Anchor End | Chain End | Anchor End |
| SPA-801 | Swivel, Small | 1550 lbs. | 1/4" - 3/8" | 0.39" | 0.62" | 0.27" | 0.39" |
| SPA-802 | Swivel, Medium | 4500 lbs. | 5/16" - 7/16" | 0.55" | 0.82" | 0.47" | 0.51" |
| SPA-803 | Swivel, Large | 5880 lbs. | 1/2" | 0.62" | 1.10" | 0.55" | 0.59" |



Snubbers & Chain Hooks

An anchor snubber is an important add-on when using an all chain rode. After setting the anchor, slip the hook onto a link of chain and tie off the 3-strand nylon tail. You can then let out additional chain with the windlass, which transfers the anchor load to the snubber from the windlass. This makes for an easier and quieter ride as the nylon tail will stretch slightly as the load of the boat on the anchor changes. We use high-strength ACCO chain hooks in our snubbers and offer these as separate items so you can build a snubber to fit your specifications.

| | |
|-----------|--|
| SPA-SNUB1 | Anchor Snubber for 1/4" Chain with 20' of 1/2" 3-Strand Nylon Line |
| SPA-SNUB2 | Anchor Snubber for 5/16" Chain with 25' of 9/16" 3-Strand Nylon Line |
| SPA-SNUB3 | Anchor Snubber for 3/8" Chain with 30' of 5/8" 3-Strand Nylon Line |
| SPA-HK1 | Chain Hook Only for 1/4" Chain |
| SPA-HK2 | Chain Hook Only for 5/16" Chain |
| SPA-HK3 | Chain Hook Only for 3/8" Chain |



Chain Markers

Color-coded chain markers make it easy to keep track of chain deployment. Available in five colors: red, blue, green, yellow and white. Supplied in bags of 10 (5/16"), or 8 (3/8" and 1/2").

| | |
|----------------|---|
| SPA-01.500.08R | Chain Markers, 5/16" Red (Bag of 10) |
| SPA-01.500.08B | Chain Markers, 5/16" Blue (Bag of 10) |
| SPA-01.500.08G | Chain Markers, 5/16" Green (Bag of 10) |
| SPA-01.500.08Y | Chain Markers, 5/16" Yellow (Bag of 10) |
| SPA-01.500.08W | Chain Markers, 5/16" White (Bag of 10) |
| SPA-01.500.10R | Chain Markers, 3/8" Red (Bag of 8) |
| SPA-01.500.10B | Chain Markers, 3/8" Blue (Bag of 8) |
| SPA-01.500.10G | Chain Markers, 3/8" Green (Bag of 8) |
| SPA-01.500.10Y | Chain Markers, 3/8" Yellow (Bag of 8) |
| SPA-01.500.10W | Chain Markers, 3/8" White (Bag of 8) |
| SPA-01.500.12R | Chain Markers, 1/2" Red (Bag of 8) |
| SPA-01.500.12B | Chain Markers, 1/2" Blue (Bag of 8) |
| SPA-01.500.12G | Chain Markers, 1/2" Green (Bag of 8) |
| SPA-01.500.12Y | Chain Markers, 1/2" Yellow (Bag of 8) |
| SPA-01.500.12W | Chain Markers, 1/2" White (Bag of 8) |

ANCHOR ROLLERS



Photo: Intrepid Yachts

Imtra's stainless steel anchor rollers are attractive and extremely durable.

All Imtra anchor rollers are made of heavy-duty stainless steel and are extremely durable. Electro-polishing removes any surface impurities and provides an attractive, smooth, bright finish that does not corrode and requires no maintenance.



Photo: MJM Yachts

Many of our rollers are sized to hold specific anchor types and sizes. Please refer to the chart on page 45 to find

the roller that best fits your boat. Imtra also offers general purpose rollers and replacement roller wheels. For more information about these products, visit www.imtra.com



General Purpose Rollers



Replacement Roller Wheels



IABR-11



IABR-16; IABR-23



IABR-20; IABR-20N



IABR-21; IABR-21N
(self launching)



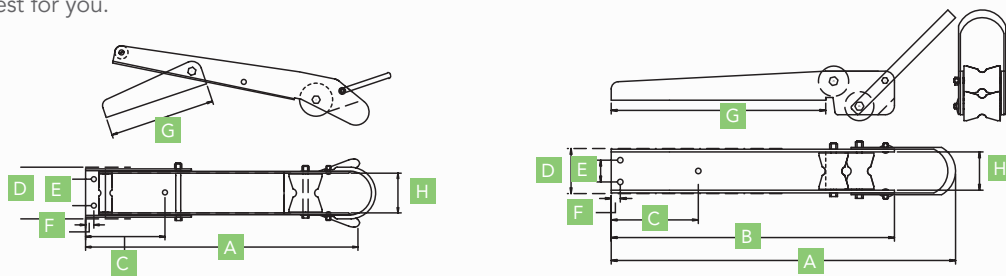
IABR-22; IABR-22N

Bow rollers to fit the most popular anchors in a range of sizes and configurations.



Roller Specifications

Many of our rollers are sized to hold specific anchor types and sizes. Use the diagrams and chart below to determine which anchor roller is best for you.



| Item # | Anchor Type | A | B | C | D | E | F | G | H |
|------------|---|-----------|---------|--------|----------|--------|------|-----------|---------|
| IABR-11 | Danforth®, other fluke anchors up to 20 lbs. | 11" | | 3" | 3" | 1 1/2" | 5/8" | 7" | 2 5/8" |
| IABR-16 | CQR®/Plow anchors up to 60 lbs. | 16" | | 4" | 3" | 1 1/2" | 5/8" | 9 3/4" | 2 5/8" |
| IABR-20 | Fluke-style anchors up to 35 lbs. | 20" | | 6" | 3 3/8" | 2" | 5/8" | 14" | 3" |
| IABR-20N | Fluke-style anchors up to 35 lbs. | 20" | | 6" | 3 3/8" | 1 1/2" | 5/8" | 14" | 3" |
| IABR-21 | Fluke anchors up to 20 lbs. | 20 5/8" | | 6" | 3 7/8" | 2" | 5/8" | 8" | 3" |
| IABR-21N | Narrow-width version of IABR-21 | 20 5/8" | | 6" | 3 3/8" | 1 1/2" | 5/8" | 8" | 2 3/4" |
| IABR-22 | Bruce, Delta® and fluke anchors up to 60 lbs. | 23 11/16" | 19 1/2" | 6" | 3 3/8" | 1 1/2" | 5/8" | 14 13/16" | 2 5/8" |
| IABR-22L | Extra-long version of IABR-22 | 27 11/16" | 23 1/2" | 6" | 3 3/8" | 1 1/2" | 5/8" | 18 13/16" | 2 5/8" |
| IABR-23 | CQR/Plow anchors from 30-60 lbs. | 23" | | 6" | 3" | 1 1/2" | 5/8" | 17" | 2 5/8" |
| IABRUCE-25 | Bruce anchors from 11-44 lbs. | 24 11/16" | | | | | | 16 11/16" | 2 5/8" |
| IACQR-20 | CQR plow anchors up to 45 lbs. | 19 5/16" | | 6" | 4" | 2" | 5/8" | 14" | 3 1/2" |
| IACQR-30 | CQR plow anchors from 45-75 lbs. | 29" | | | | | | 23" | 4" |
| IAEL-40 | Bruce anchors from 66-110 lbs. | 39" | | 12" | 5 15/16" | 3" | | 28" | 5 1/4" |
| IAELTA-20 | Delta anchors from 14-44 lbs. | 18 1/2" | | 6" | 3" | 1 1/2" | 5/8" | 13 3/8" | 2 1/4" |
| IAELTA-23 | Delta anchors from 30-60 lbs. | 23 5/16" | | 7 3/4" | 4" | 2" | 5/8" | 12 3/8" | 3 1/2" |
| IAE-8 | Fluke anchors up to 50 lbs. | 18 1/2" | | 6 1/2" | 6 1/2" | | | 14" | 3 5/16" |

REFERENCE GUIDE

Our commitment to customer service and support.

Imtra's focus on service and extensive product knowledge are what set us apart. We have built our business on having the products and replacement parts you need available for prompt delivery.



The accessible staff at Imtra headquarters in New Bedford, Massachusetts has the training and experience to discuss your requirements and answer any questions you may have.

Visit www.imtra.com

Imtra's new, redesigned website makes it easier than ever to find a wealth of product information and technical support! Search Imtra's knowledge base for maintenance tips, installation advice, downloadable owner's manuals, and much more.



Photo: Grady-White

Glossary of Anchoring Terms

Capstan – Often referred to as a drum, rope drum, or warping drum. The capstan is primarily used for hauling rope.

Chainstopper – Similarly, chain compressor. Located between the winch and bow roller. Secures chain and anchor and takes the load off the winch/windlass. Highly recommended for systems utilizing all chain and for semi-automatic rope/chain systems.

Deck Clearance – The allowable thickness of the deck where the windlass will be mounted.

Free Fall – Release of the winch clutch mechanism allowing the anchor and rode (chain or rope/chain) to run out freely with no engagement of winch gearbox or motor.

Gypsy – Often referred to as chainwheel or wildcat. A special wheel with pockets, to accommodate a specified chain size, for hauling up the chain and anchor. With automatic rope/chain systems the gypsy is designed to haul both rope and chain.

Hauling – Often referred to as weighing or lifting. The operation of lifting the anchor and rode.

Horizontal – Pertaining to the winch or windlass. Drive shaft, capstan and gypsy are positioned horizontally to the deck.

Manual Override – A means of manually cranking the winch to haul in the rode and anchor should a failure occur in the motor, gearbox or power supply.

Power Rating – Sometimes referred to as rated lift or maximum load. The maximum operating load that could be applied to the windlass (the load the windlass would normally be subjected to is substantially less).

Retrieval Speed – The speed at which the anchor rode will be hauled in by the windlass.

Rode – The line that secures the boat to the anchor. This may consist of all chain, all rope, or a combination of rope and chain.

Self Launching Roller – A roller that will deploy the anchor when the anchor rode is slackened.

Vertical – Pertaining to the winch or windlass. The drive shaft, capstan and gypsy are positioned vertically to the deck.

Windlass – A machine for raising a weight by winding a rope and/or chain around a drum or chainwheel, driven by a crank, motor, etc.

Photo Credits

Imtra would like to thank the following boatbuilders, photographers, and companies for allowing us to use their images in this catalog:

- American Tugs, CW Hood Yachts, Cabo Yachts, Caliber Yachts, Carver Yacht Group, Cruiser Yachts, Fleming Yachts, Fontaine-Pajot, Grady-White, Grand Banks, The Hinckley Company, Hunt Yachts, Hunter Yachts, Hylas Yachts, Intrepid Yachts, Island Packet, Krogan Express, MJM Yachts, Nordhavn Yachts, Onne Van der Wal Photography, Pearson Yachts, Sabre Yachts, Sea Ray Inc., Striper Boats, Shutterstock Inc., Sunsail USA, Tiara Yachts, Vicem Yachts.

Front Cover Boat Photos (L-R): Island Packet, Tiara Yachts, American Tugs (Background): Shutterstock Inc.

For technical advice, parts, downloads and product details please visit www.imtra.com

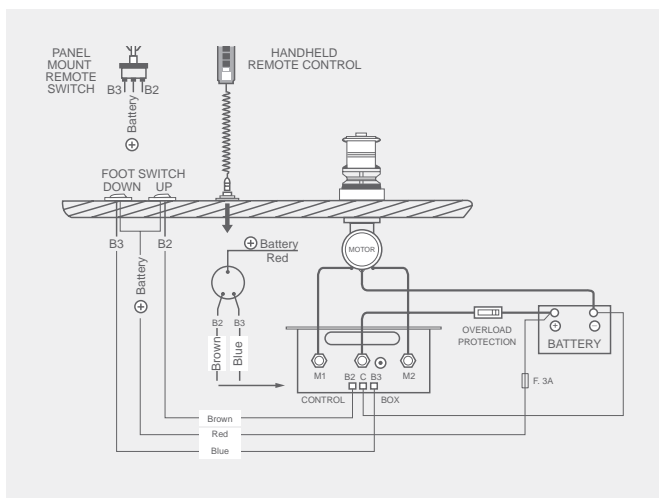
Conductor Sizes (Gauge) for 10% Voltage Drop

| | | 12 Volts | | | | | | | | | | | | | | |
|--------------------------|--|--|----|----|----|----|----|----|----|----|-----|-----|-----|-----|-----|-----|
| Total Current On Circuit | | Length of conductor from source of current to windlass and back to source - in feet. | | | | | | | | | | | | | | |
| | | 20 | 25 | 30 | 40 | 50 | 60 | 70 | 80 | 90 | 100 | 110 | 120 | 130 | 140 | 150 |
| 30 Amps | | 12 | 10 | 10 | 8 | 8 | 6 | 6 | 6 | 6 | 4 | 4 | 4 | 4 | 2 | 2 |
| 40 Amps | | 10 | 10 | 8 | 8 | 6 | 6 | 6 | 4 | 4 | 4 | 2 | 2 | 2 | 2 | 2 |
| 50 Amps | | 10 | 8 | 8 | 6 | 6 | 4 | 4 | 4 | 2 | 2 | 2 | 2 | 2 | 1 | 1 |
| 60 Amps | | 8 | 8 | 6 | 6 | 4 | 4 | 2 | 2 | 2 | 2 | 2 | 1 | 1 | 1 | 0 |
| 70 Amps | | 8 | 6 | 6 | 6 | 4 | 2 | 2 | 2 | 2 | 1 | 1 | 1 | 0 | 0 | 0 |
| 80 Amps | | 8 | 6 | 6 | 4 | 4 | 2 | 2 | 2 | 1 | 1 | 0 | 0 | 0 | 2/0 | 2/0 |
| 90 Amps | | 6 | 6 | 6 | 4 | 2 | 2 | 2 | 1 | 1 | 0 | 0 | 0 | 2/0 | 2/0 | 2/0 |
| 100 Amps | | 6 | 6 | 4 | 4 | 2 | 2 | 1 | 1 | 0 | 0 | 0 | 2/0 | 2/0 | 2/0 | 3/0 |

| | | 24 Volts | | | | | | | | | | | | | | |
|--------------------------|--|--|----|----|----|----|----|----|----|----|-----|-----|-----|-----|-----|-----|
| Total Current On Circuit | | Length of conductor from source of current to windlass and back to source - in feet. | | | | | | | | | | | | | | |
| | | 20 | 25 | 30 | 40 | 50 | 60 | 70 | 80 | 90 | 100 | 110 | 120 | 130 | 140 | 150 |
| 30 Amps | | 14 | 14 | 12 | 12 | 10 | 10 | 8 | 8 | 8 | 8 | 8 | 6 | 6 | 6 | 6 |
| 40 Amps | | 14 | 12 | 12 | 10 | 10 | 8 | 8 | 8 | 6 | 6 | 6 | 6 | 6 | 6 | 4 |
| 50 Amps | | 12 | 12 | 10 | 10 | 8 | 8 | 6 | 6 | 6 | 6 | 6 | 4 | 4 | 4 | 4 |
| 60 Amps | | 12 | 10 | 10 | 8 | 8 | 6 | 6 | 6 | 6 | 4 | 4 | 4 | 4 | 2 | 2 |
| 70 Amps | | 10 | 10 | 8 | 8 | 6 | 6 | 6 | 6 | 4 | 4 | 4 | 2 | 2 | 2 | 2 |
| 80 Amps | | 10 | 10 | 8 | 8 | 6 | 6 | 6 | 4 | 4 | 4 | 2 | 2 | 2 | 2 | 2 |
| 90 Amps | | 10 | 8 | 8 | 6 | 6 | 6 | 4 | 4 | 4 | 2 | 2 | 2 | 2 | 2 | 2 |
| 100 Amps | | 10 | 8 | 8 | 6 | 6 | 4 | 4 | 4 | 2 | 2 | 2 | 2 | 2 | 1 | 1 |

Based on minimum CM Area ©2003 American Boat & Yacht Council. In the event of a conflict between a voltage drop calculation for wiring sizes and these ampacity tables, use the larger wire size.

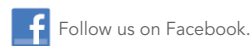
TYPICAL WIRING DIAGRAM



IMTRA is a registered trademark of Imtra Corporation.
 ACCO is a registered trademark of FKI Industries.
 AUTOANCHOR is a trademark of RMSD Limited.
 CQR and DELTA are registered trademarks of Lewmar, Ltd.
 DANFORTH is a registered trademark of Rule Industries.
 DELRIN is a registered trademark of E.I. du Pont de Nemours and Company.
 Design: Sewell Creative Color Illustrations: mirtoart.com



Imtra Corporation
 30 Samuel Barnett Boulevard, New Bedford, MA 02745 U.S.A.
 Phone: 508.995.7000 Fax: 508.998.5359



imtra[®]
MARINE PRODUCTS



Photo: Vicem Yachts

Imtra Corporation
30 Samuel Barnet Boulevard, New Bedford, MA 02745
Phone: 508.995.7000 Fax: 508.998.5359